

PUDT4P / PURDT4

(D)	MONTAGEANLEITUNG:	SELBSTSTÄNDIG STEHENDE SEITENWAND
(GB)	INSTALLATION INSTRUCTIONS:	INDEPENDENT, UPRIGHT FIXED PANEL
(F)	NOTICE DE MONTAGE:	PAROI FIXE POUR MONTAGE SEULE
(CZ)	NÁVOD K MONTÁŽI:	SAMOSTATNĚ STOJÍCÍ BOČNÍ STĚNA
(PL)	INSTRUKCJA MONTAŻU:	ODDZIELNIE STOJĄCA ŚCIANA BOCZNA
(SK)	NÁVOD NA MONTÁŽ:	SAMOSTATNE STOJACA BOČNÁ STENA
(H)	SZERELÉSI ÚTMUTATÓ:	KÜLÖNÁLLÓ OLDALFAL
(E)	INSTRUCCIONES DE MONTAJE:	PARED LATERAL PUESTA AISLADAMENTE

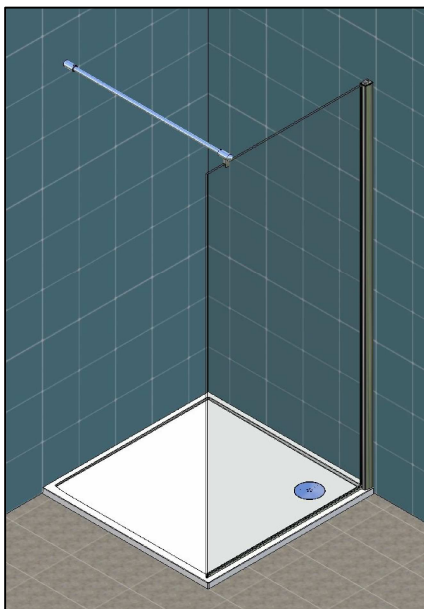

PUDT4P

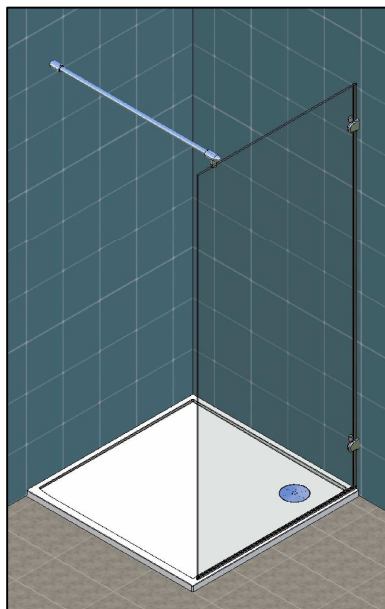
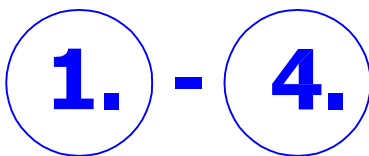

PURDT4

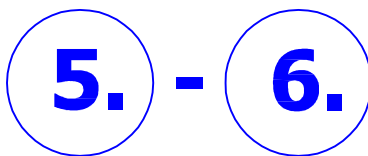

ERONAL®

Benötigtes Werkzeug:
 Necessary tools:
 Outil Nécessaire:
 Nářadí potřebné pro montáž:

Potrzebne narzędzia:
 Potrebne náradie:
 Szükséges szerszámok:
 Herramientas necesarias:

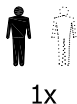

1x

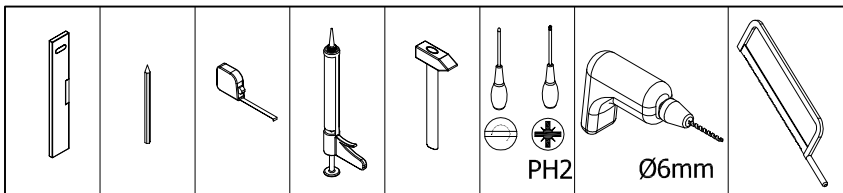

PUDT4P

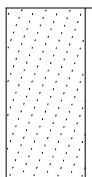

50352

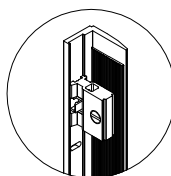

50459

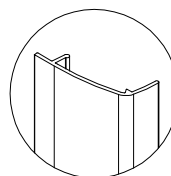

PURDT4

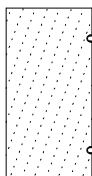

50552

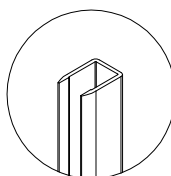

Zubehör:
 Equipment:
 Accessoires:
 Příslušenství:

Dodatki:
 Príslušenstvo:
 Alkatrészek:
 Accesorios:

<p>PUDT4P+BSMV</p>	<p>1 x 11221</p>	<p>4 x 14139 4.2 x 50mm</p>	<p>4 x 16000 Ø 6mm</p>	<p>L/R 2 x 51592-93</p>	<p>2x 51209</p>
<p>PURDT4+BSMV</p>	<p>1 x 11221</p>	<p>2 x 14139 4.2 x 50mm</p>	<p>2 x 14095 Ø 6mm</p>	<p>2x 51209</p>	<p>5 2 x 54037</p>

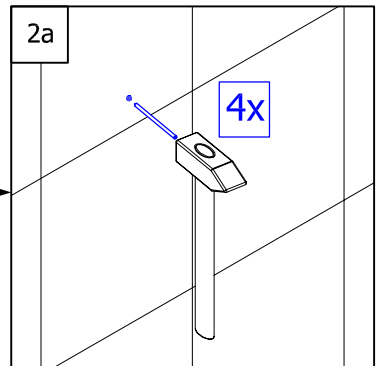
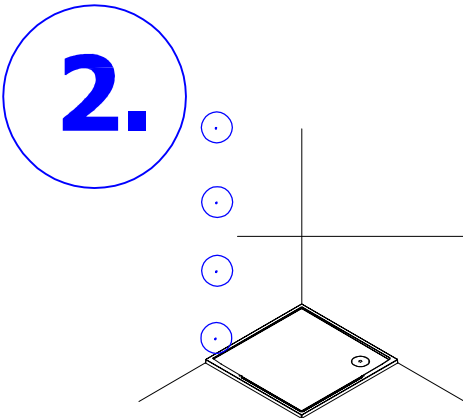
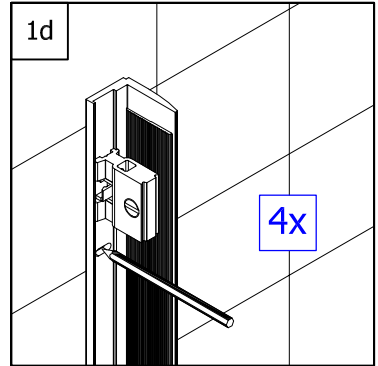
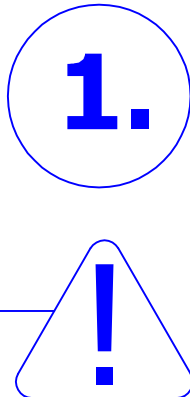
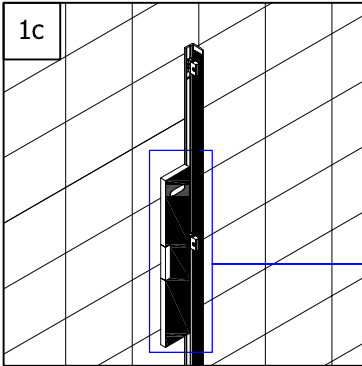
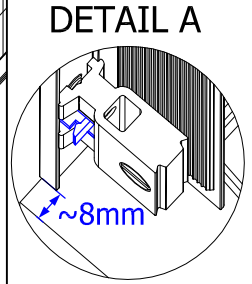
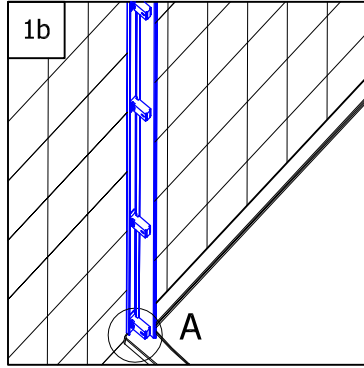
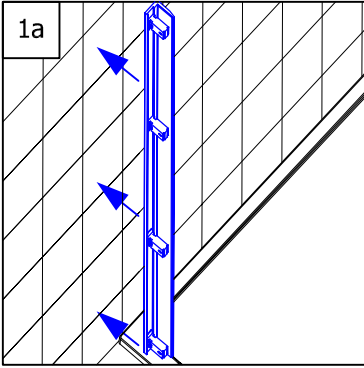

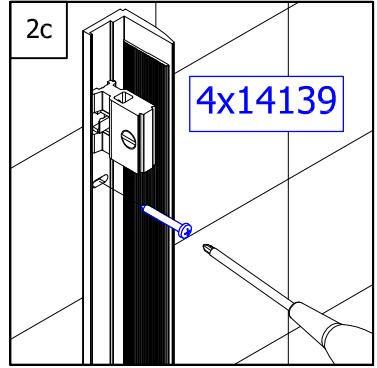
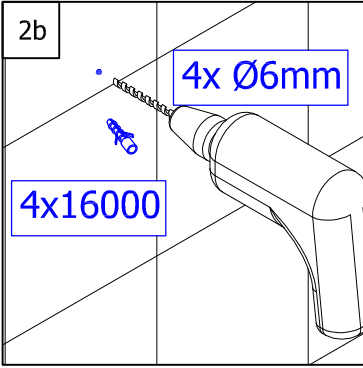

3.

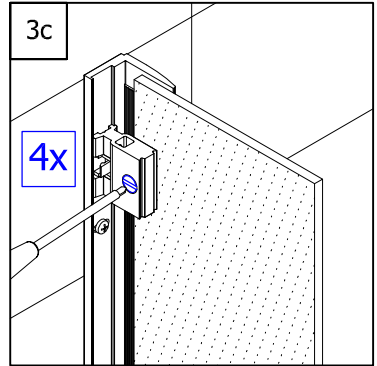
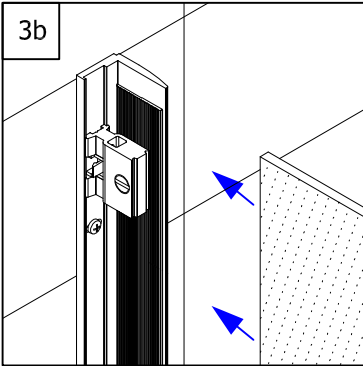
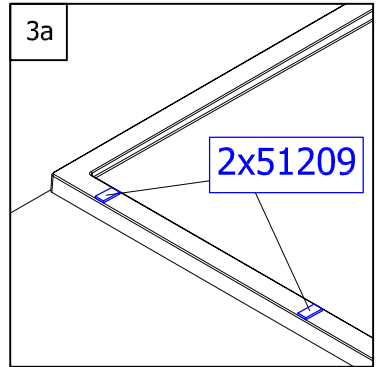
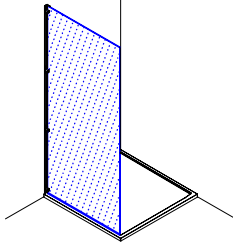

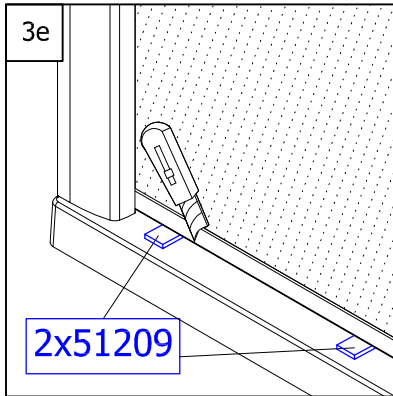
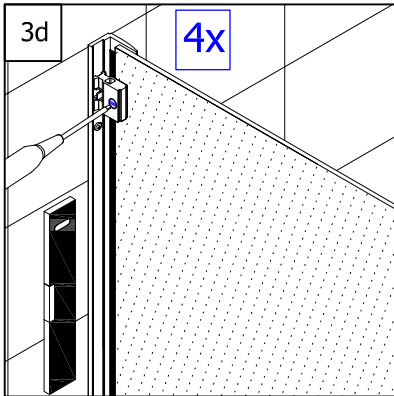

4.

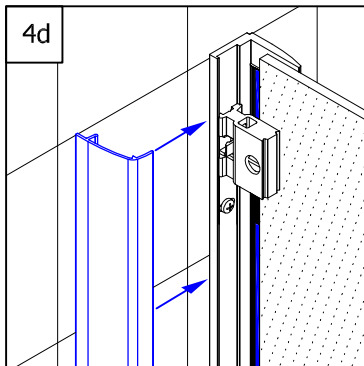
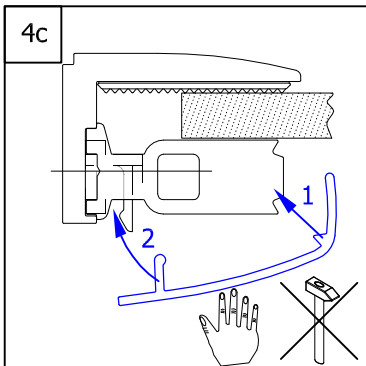
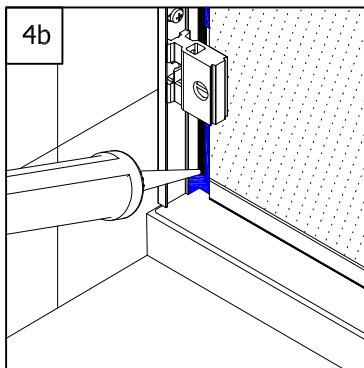
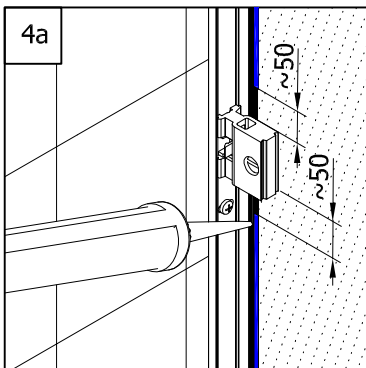

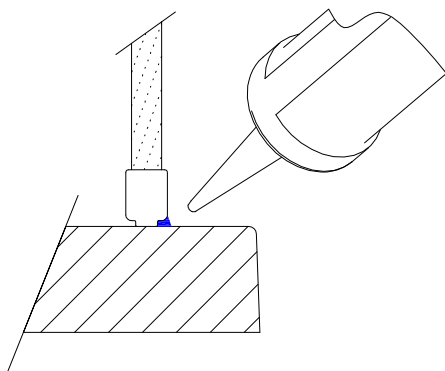
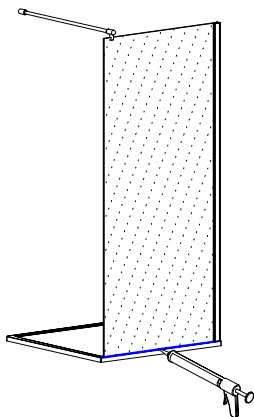
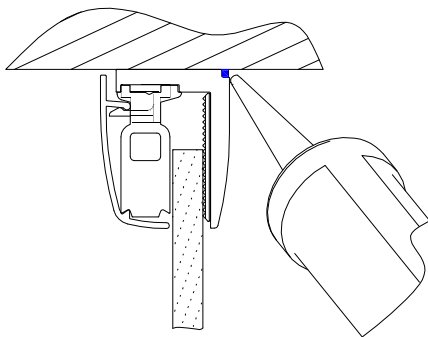
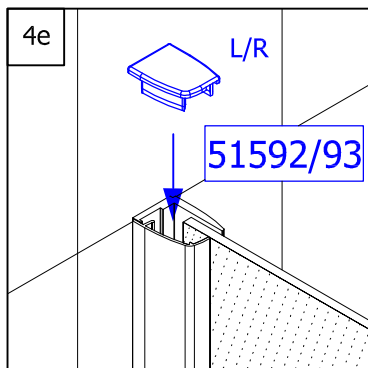

Achtung! Nur Sanitär-Silikon - bakterizid und fungizid eingestellt verwenden.

Caution! Use only bactericidal and fungicide sanitary silicone.

Attention! N'utiliser que du silicone sanitaire bactéricide et fongicide.

Pozor! Používejte pouze baktericidní a fungicidní sanitární silikon.

Uwaga! Stosować tylko silikon sanitarny - bakterio- i grzybobójczy.

Pozor! Užívajte pouze baktericidný a fungicidný sanitárny silikón.

Figyelem! Csak szaniter sziloplaszt - baktérium és gombamentes - használata megengedett.

Cuidado! Utilizar solamente silicona sanitaria bactericida y fungicida.

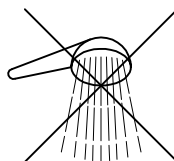

PUDT4P

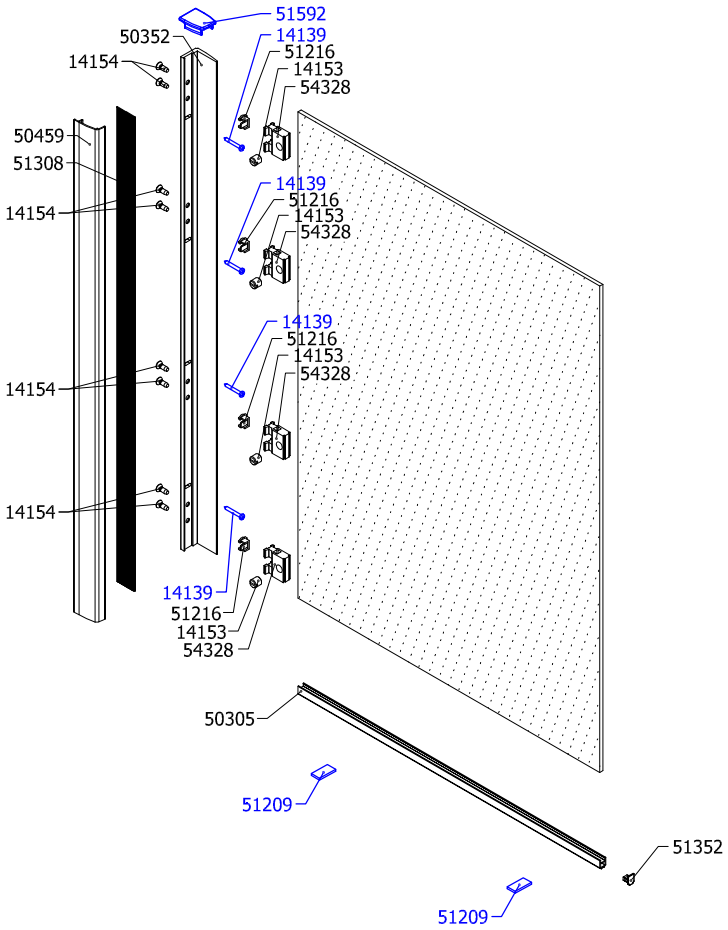

5.

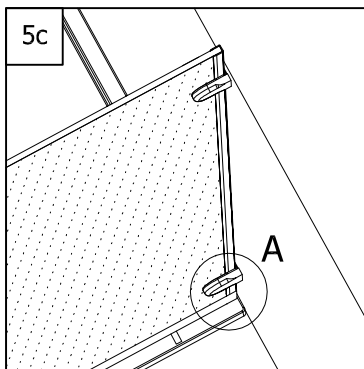
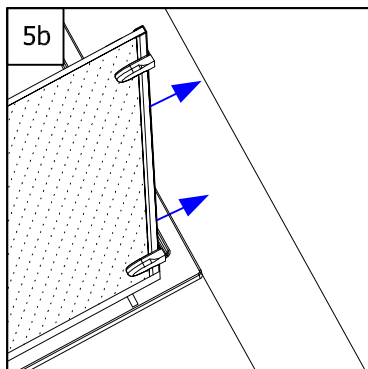
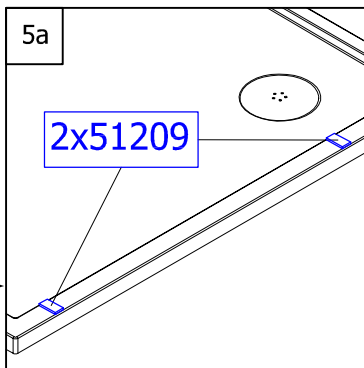
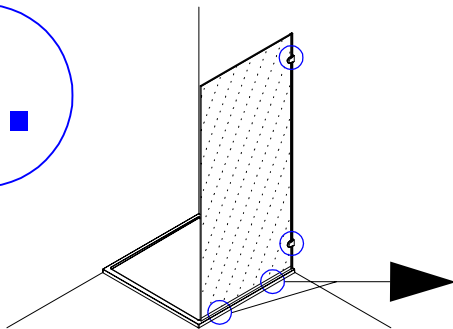

DETAIL A

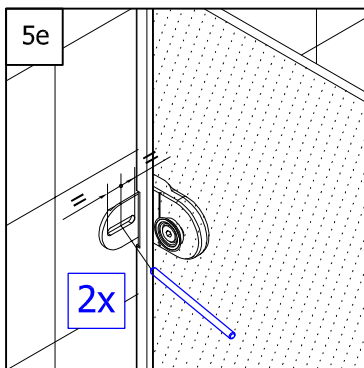
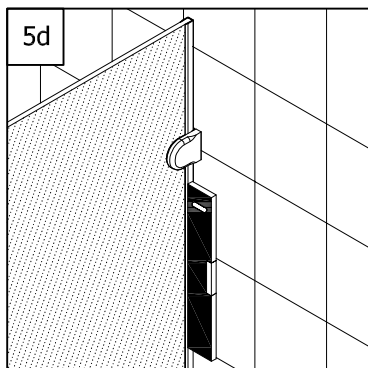
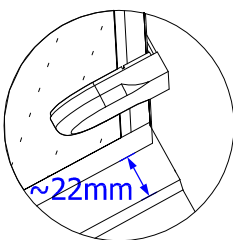

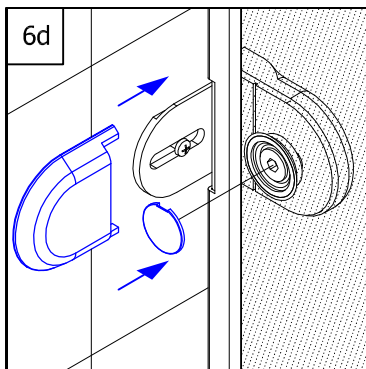
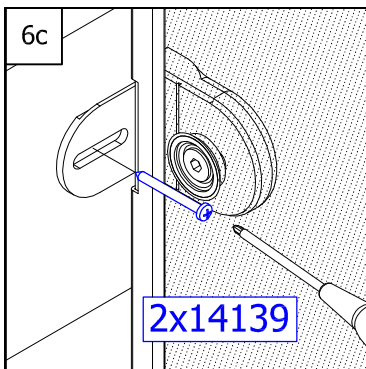
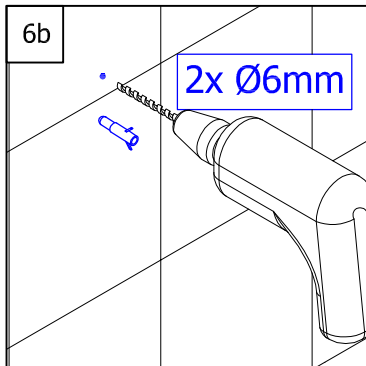
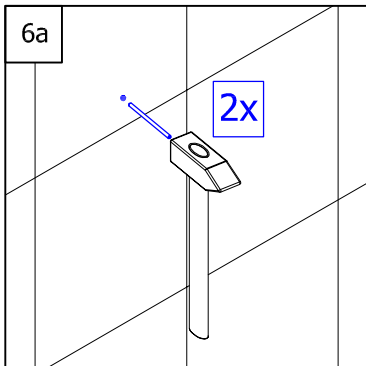

6.

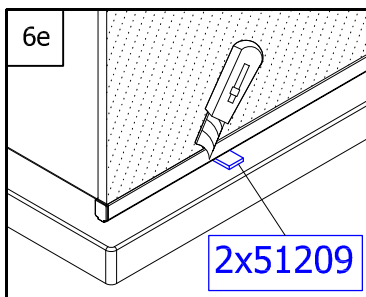
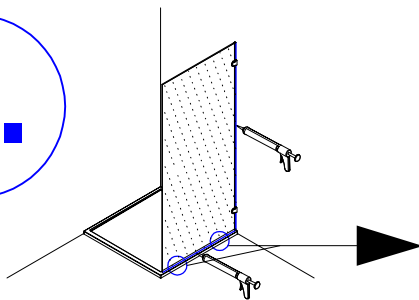

Achtung! Nur Sanitär-Silikon - bakterizid und fungizid eingestellt verwenden.

Caution! Use only bactericidal and fungicide sanitary silicone.

Attention! N'utiliser que du silicone sanitaire bactéricide et fongicide.

Pozor! Používejte pouze baktericidní a fungicidní sanitární silikon.

Uwaga! Stosować tylko silikon sanitarny - bakterio i grzybobójczy.

Pozor! Užívajte pouze baktericidný a fungicidný sanitárny silikón.

Figyelem! Csak szaniter sziloplaszt - baktérium és gombamentes - használatra megengedett.

Cuidado! Utilizar solamente silicona sanitaria bactericida y fungicida.

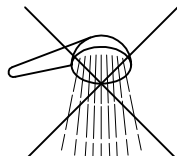
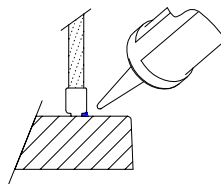

PURDT4

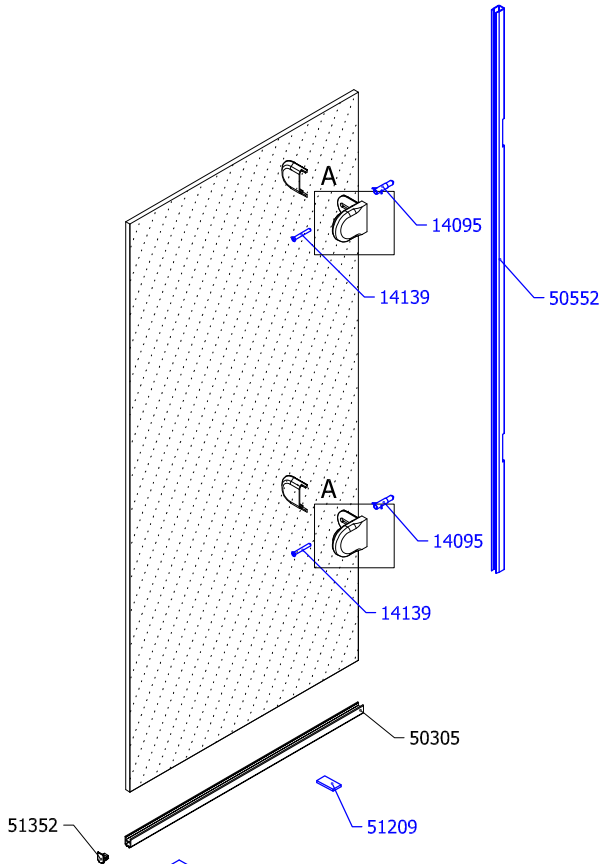

DETAIL A

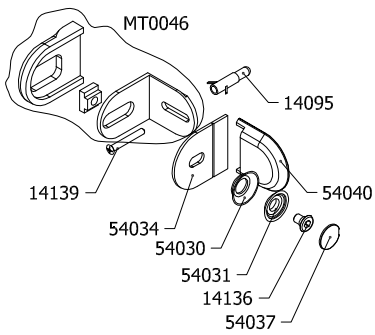

QUALITY CONTROL:

- D** Falls Sie Reklamationen haben, oder Sie unzufrieden mit Ihrem RONAL Produkt sind, beschreiben Sie bitte unten auf diesem Blatt den Produktfehler und übergeben Sie dieses Dokument Ihrem Verkäufer, oder direkt der Firma RONAL. Diese Information hilft uns, die Qualität von unseren Produkten weiter zu verbessern.
- GB** In case of a complaint or Your dissatisfaction with the RONAL product, please describe the defect below and pass this document to Your vendor, or directly to the RONAL company. This information will help us in the next increase of the quality of our products.
- F** En cas de réclamations lors de la livraison ou l'installation de votre paroi de douche RONAL, veuillez, s'il vous plaît, noter vos remarques au bas de la feuille et transmettre les informations à votre revendeur. Elles nous permettront d'améliorer notre qualité et par la même notre service.
- CZ** V případě reklamace, či Vaší nespokojenosti s výrobkem RONAL popište prosím ve spodní části tohoto listu závadu a dokument prosím odevzdejte Vašemu prodejci nebo přímo firmě RONAL. Tato informace nám pomůže v dalším zvýšení kvality našich výrobků.
- PL** Reklamacje , oraz inne niezgoności związane z produktem RONAL prosimy przekazywać sprzedawcy na załącznym druku.
- SK** V prípade reklamácie, alebo Vašej nespokojnosti s výrobkom RONAL, popište prosím v spodnej časti tohto listu závalu a dokument prosím odovzdajte Vašemu prodejci, alebo priamo firme RONAL. Táto informácia nám pomôže v ďalšom zvýšení kvality našich výrobkov.
- H** Abban az esetben ha reklamációja vagy panasza van az Ön által vásárolt RONAL termékkel, úgy azt írja meg a lap alján található helyre és adja át a kereskedőjének, vagy küldje el közvetlenül a RONAL cégnek! Ez az információ segít nekünk termékeink minőségének javításában.
- E** En caso de reclamaciones ó si no está satisfecho con su producto RONAL, por favor describan en la parte inferior de esta hoja el fallo del producto y entreguen este documento a su vendedor ó directamente a la empresa RONAL. Esta información nos ayuda a seguir mejorando la calidad de nuestros productos.

.....

.....

.....

.....

.....

.....

.....

.....

.....

.....

.....