

QUALITY CONTROL:

- D** Falls Sie Reklamationen haben, oder Sie unzufrieden mit Ihrem RONAL Produkt sind, beschreiben Sie bitte unten auf diesem Blatt den Produktfehler und übergeben Sie dieses Dokument Ihrem Verkäufer, oder direkt der Firma RONAL. Diese Information hilft uns, die Qualität von unseren Produkten weiter zu verbessern.
- GB** In case of a complaint or Your dissatisfaction with the RONAL product, please describe the defect below and pass this document to Your vendor, or directly to the RONAL company. This information will help us in the next increase of the quality of our products.
- F** En cas de réclamations lors de la livraison ou l'installation de votre paroi de douche RONAL, veuillez, s'il vous plaît, noter vos remarques au bas de la feuille et transmettre les informations à votre revendeur. Elles nous permettrons d'améliorer notre qualité et par la même notre service.
- CZ** V případě reklamace, či Vaší nespokojenosti s výrobkem RONAL popište prosím ve spodní části tohoto listu závadu a dokument prosím odevzdejte Vašemu prodejci nebo přímo firmě RONAL. Tato informace nám pomůže v dalším zvýšení kvality našich výrobků.
- PL** Reklamacje , oraz inne niezgoności związane z produktem RONAL prosimy przekazywać sprzedawcy na załącznym druku.
- SK** V prípade reklamácie, alebo Vašej nespokojnosti s výrobkom RONAL, popište prosím v spodnej časti tohto listu závadu a dokument prosím odovzdajte Vašemu prodejci, alebo priamo firme RONAL. Táto informácia nám pomôže v ďalšom zvýšení kvality našich výrobkov.
- H** Abban az esetben ha reklamációja vagy panasza van az Ön által vásárolt RONAL termékkel, úgy azt írja meg a lap alján található helyre és adja át a kereskedőjének, vagy küldje el közvetlenül a RONAL cégnek! Ez az információ segít nekünk termékeink minőségének javításában.
- E** En caso de reclamaciones ó si no está satisfecho con su producto RONAL, por favor describan en la parte inferior de esta hoja el fallo del producto y entreguen este documento a su vendedor ó directamente a la empresa RONAL. Esta información nos ayuda a seguir mejorando la calidad de nuestros productos.

.....

.....

.....

.....

.....

.....

.....

.....

.....

TOPP+TOPP/TOPF

- D** MONTAGEANLEITUNG: DREHTÜR + SEITENWAND / DREHTÜR
- GB** INSTALLATION INSTRUCTIONS: PIVOT DOOR + FIXED PANEL / PIVOT DOOR
- F** NOTICE DE MONTAGE: PORTE PIVOTANTE + PAROI FIXE / PORTE PIVOTANTE
- CZ** NÁVOD K MONTÁŽI: OTOČNÉ DVEŘE + BOČNÍ STĚNA / OTOČNÉ DVEŘE
- PL** INSTRUKCJA MONTAŻU: 1-CZĘCIOWE DRZWI OBROTOWE + ŚCIANKA BOCZNA / 1-CZĘCIOWE DRZWI OBROTOWE
- SK** NÁVOD NA MONTÁŽ: JEDNOKRÍDLOVÉ DVERE + BOČNÁ STENA / JEDNOKRÍDLOVÉ DVERE
- H** SZERELÉSI ÚTMUTATÓ: NYÍLÓAJTÓ 1-RÉSZES + OLDALFAL 90 ° / NYÍLÓAJTÓ 1-RÉSZES
- E** INSTRUCCIONES DE MONTAJE: PUERTA ABATIBLE + LATERAL FIJO / PUERTA ABATIBLE

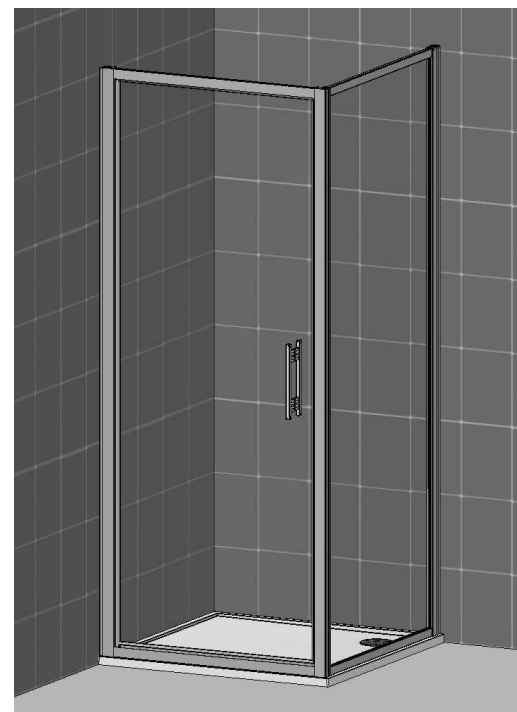

1. - 9. 10. - 14.

RONAL[®]

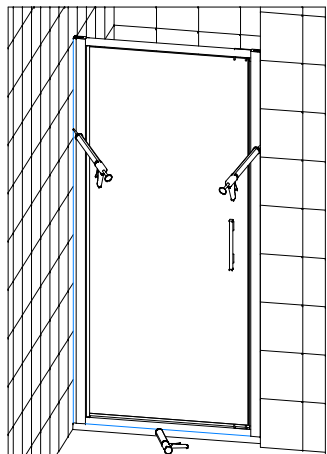

14a

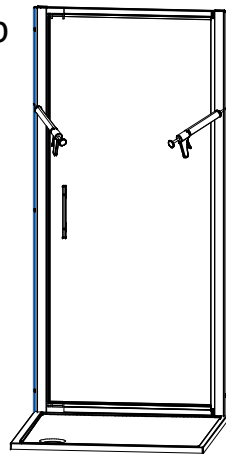

14b

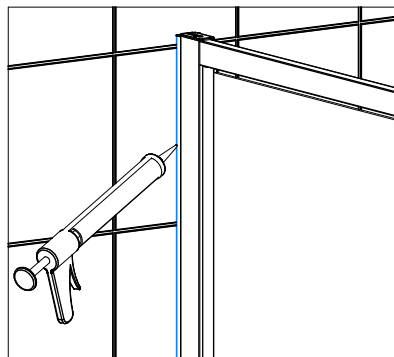

14c

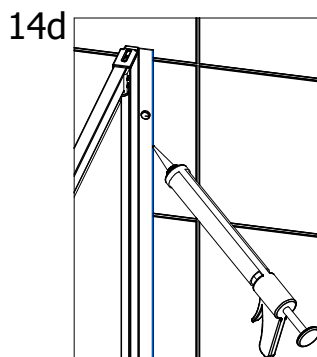

14d

Achtung! Nur Sanitär-Silikon - bakterizid und fungizid eingestellt verwenden.

Caution! Use only bactericidal and fungicide sanitary silicone.

Attention! N'utiliser que du silicone sanitaire bactéricide et fongicide.

Pozor! Používejte pouze baktericidní a fungicidní sanitární silikon.

Uwaga! Stosować tylko silikon sanitarny - bakterio i grzybobójczy.

Pozor! Užívajte pouze baktericidný a fungicidný sanitárny silikon.

Figyelem! Csak szaniter szilopasz - baktérium és gombamentes - használata megengedett.

Cuidado! Utilizar solamente silicona sanitaria bactericida y fungicida.

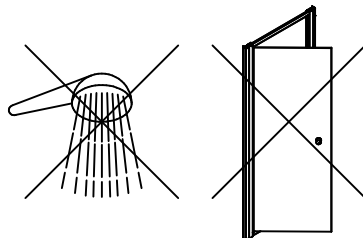

14.

(D) Verstellbereich für Montage auf Duschwanne oder bodenebenen.

(GB) Presetting range for assamblage on the shower tray or on the pavage.

(F) Plage de réglage pour une pose sur receveur ou à l'italienne.

(CZ) Přestavná míry pro montáž na vaničku nebo na dlažbu.

(PL) Zakres regulacji do montażu na brodziku lub bezpośrednio na posadzce.

(SK) Prestavná šírka pre montáž na vaničku alebo podlahu.

(H) Állíthatóság zuhanytálcára vagy padlóra való építésnél.

(E) Zona de ajuste en platos de ducha o a ras de suelo.

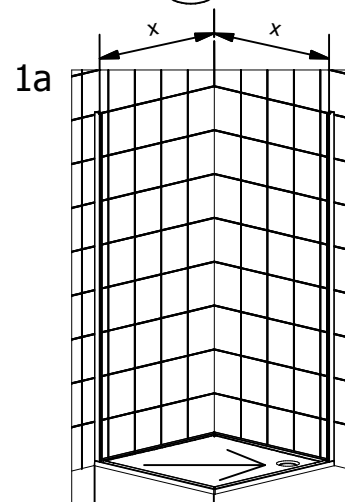

1a

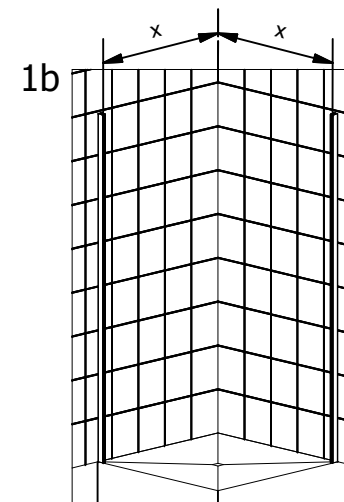

1b

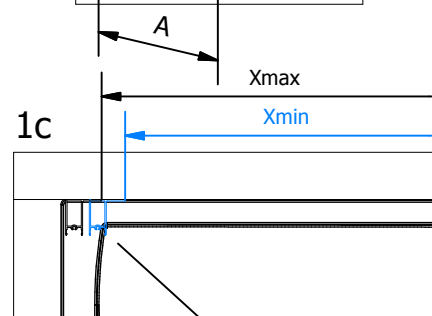

1c

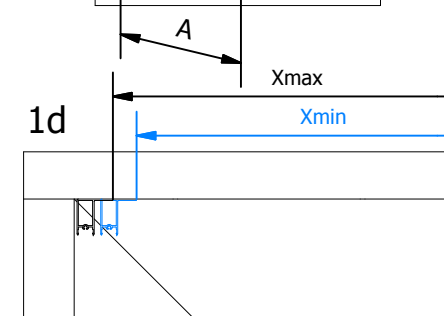

1d

A	X min	X max
800	734	759
900	834	859
1000	934	959

1.

2a

2b

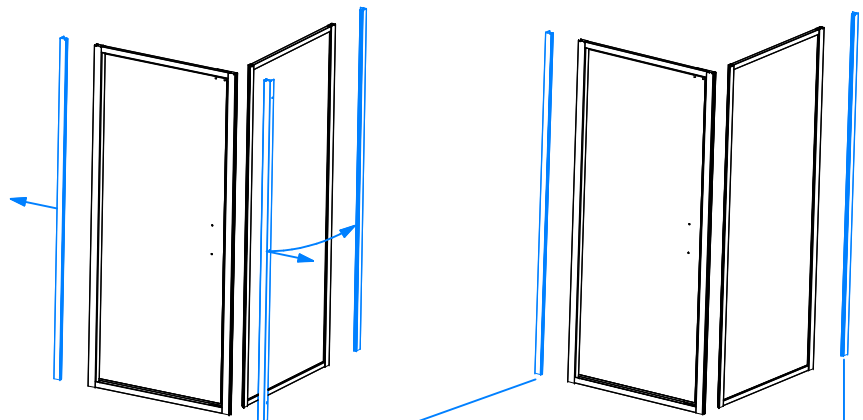

2c

2d

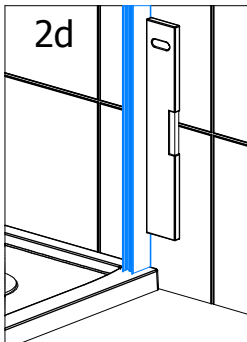
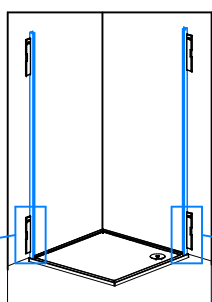
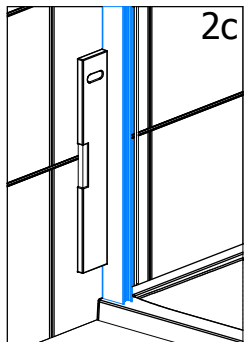

2e

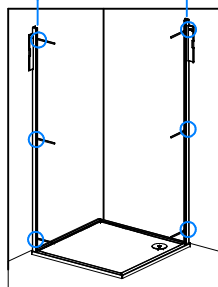
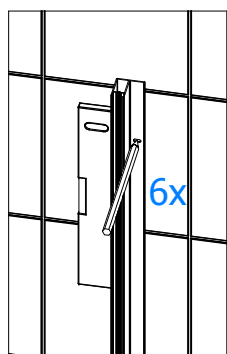

6x

2.

13a

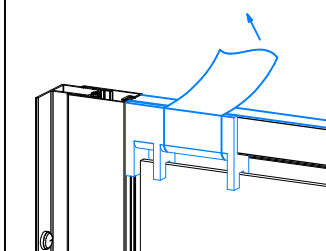

13b

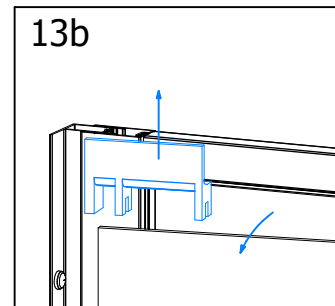

13c

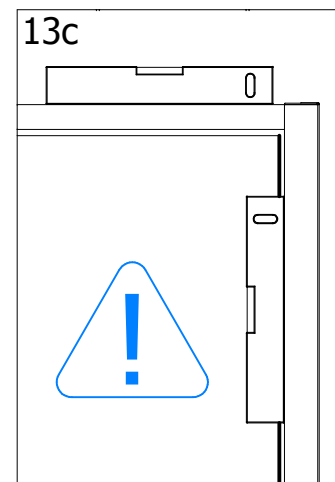

13.

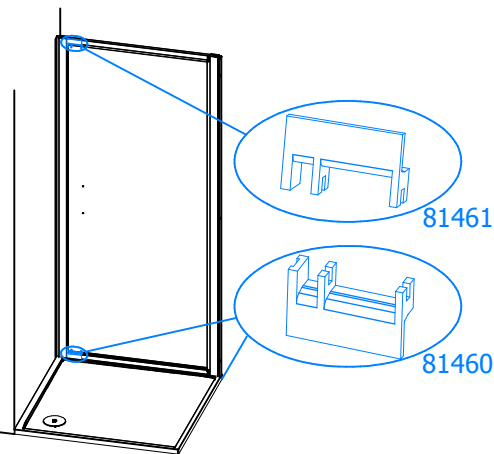

81461

81460

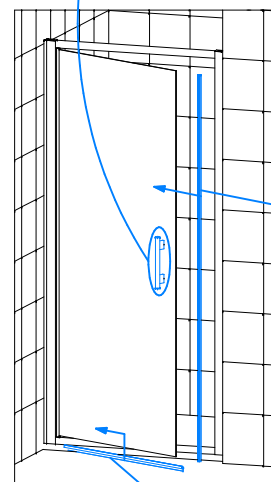
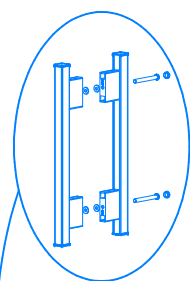

42356

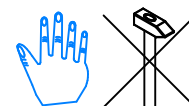

82402

12.

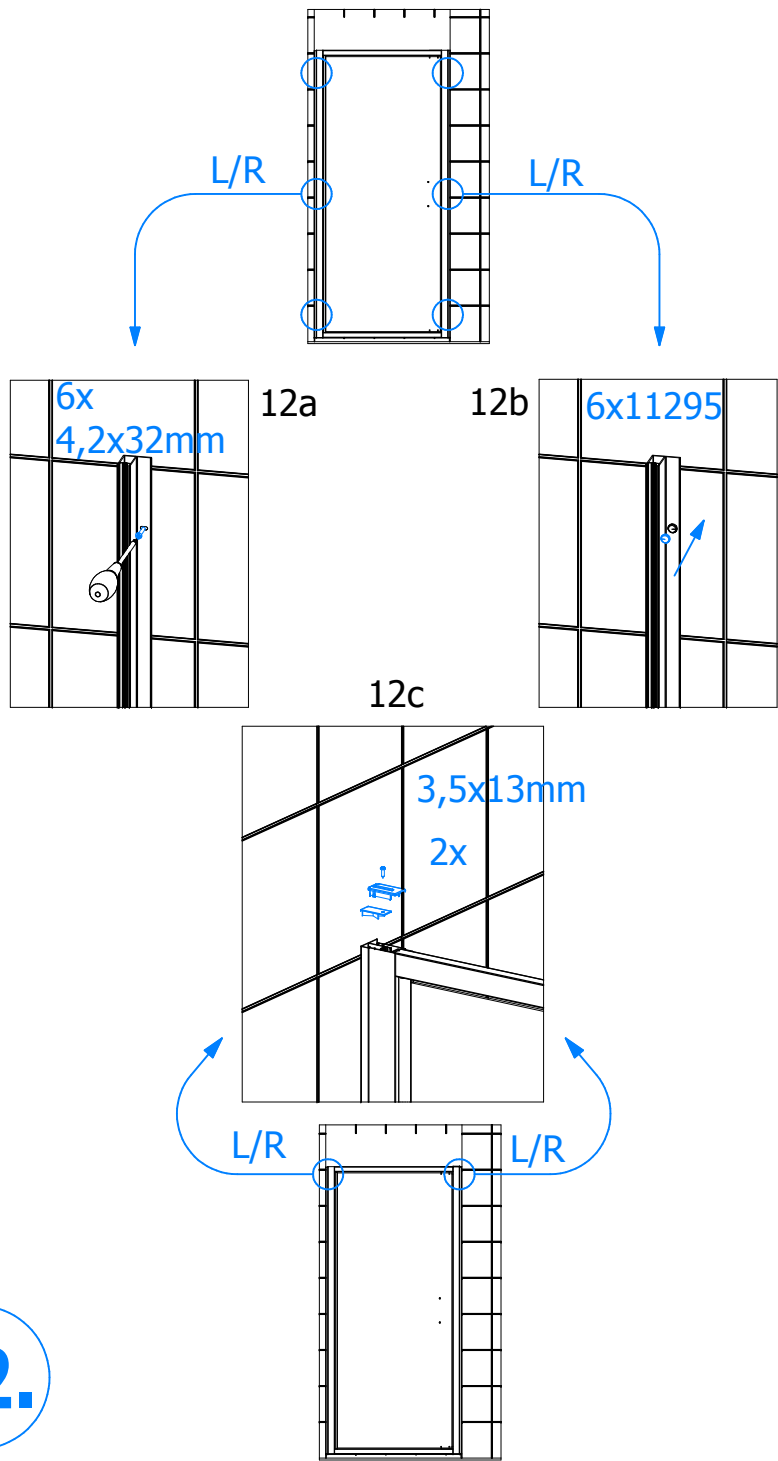

3.

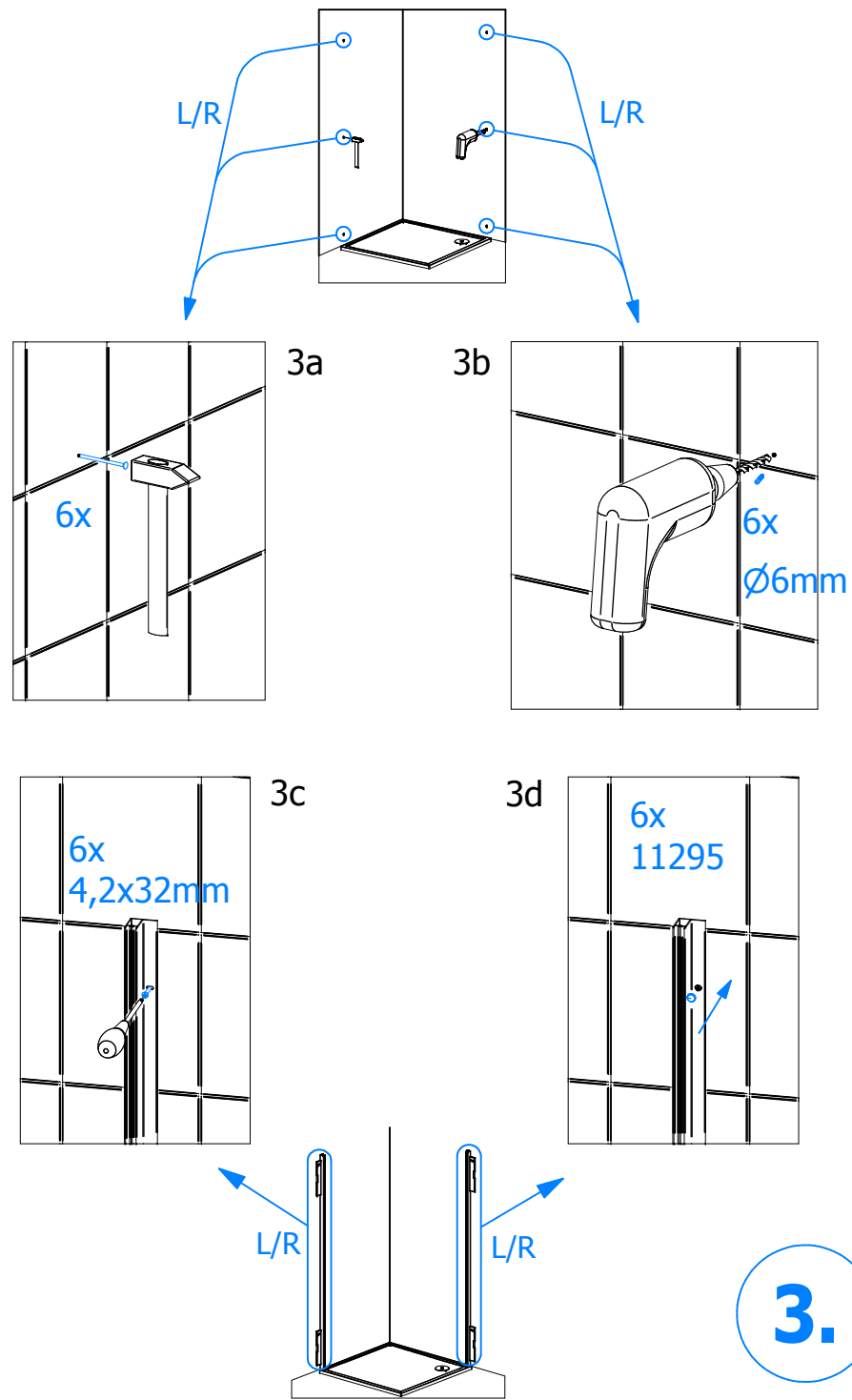

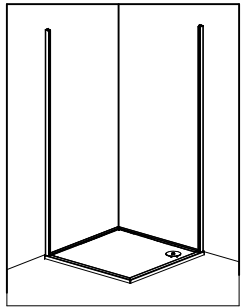

TOPP

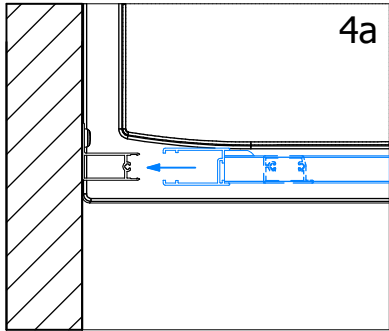
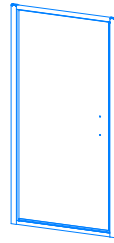

4a

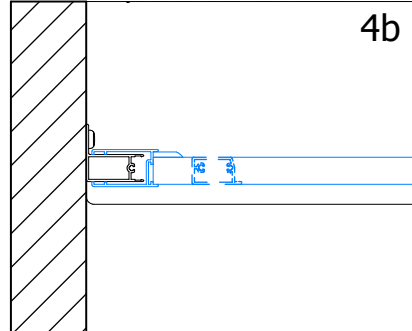

4b

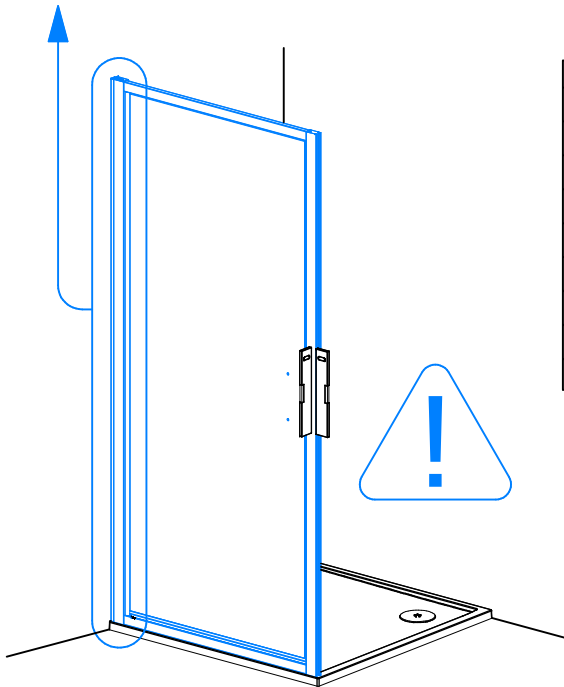

4.

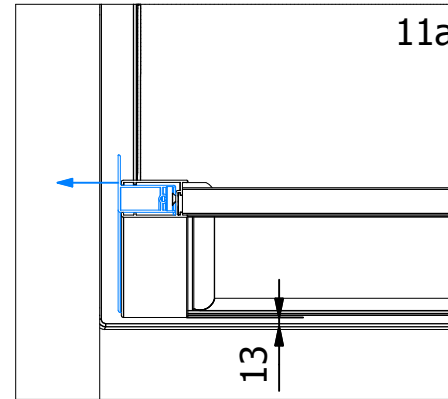
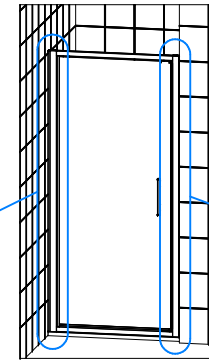
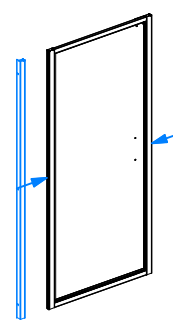

11a

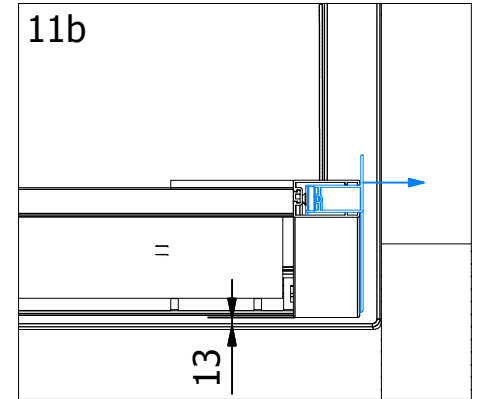

11b

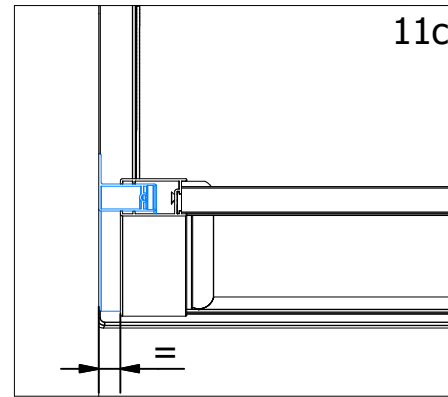

11c

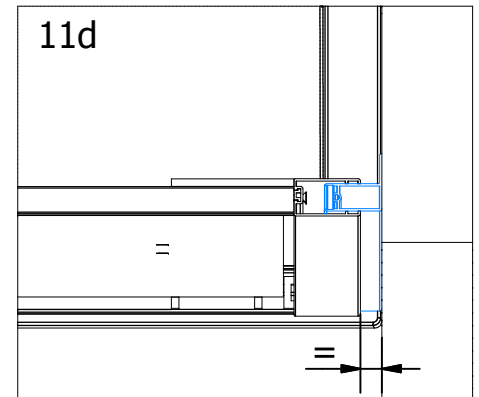

11d

11.

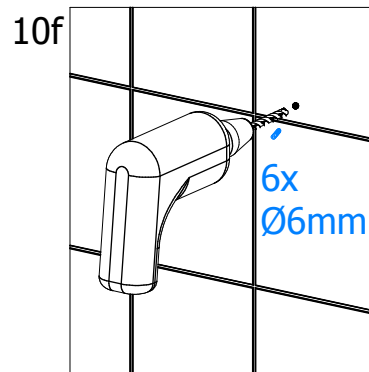
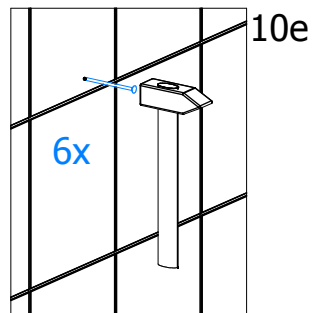
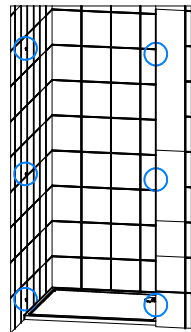
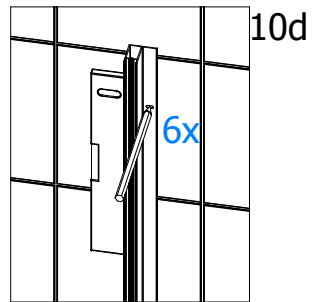
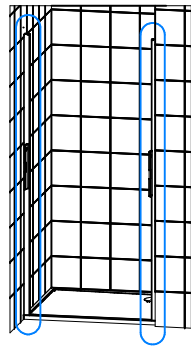
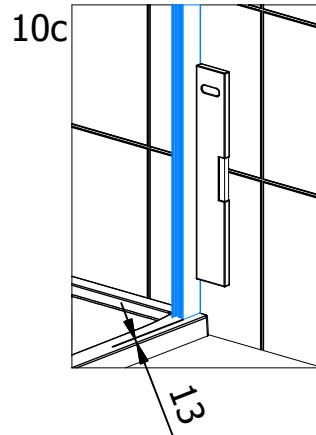
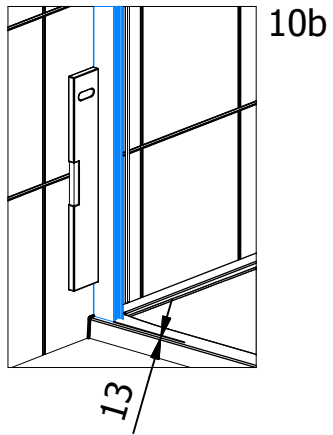
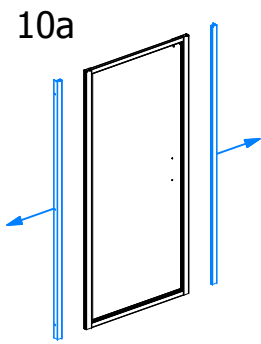

10.

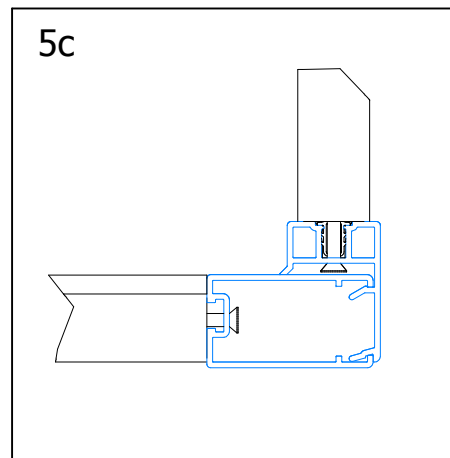
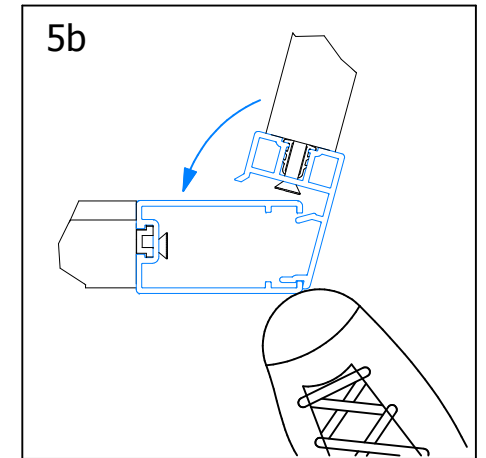
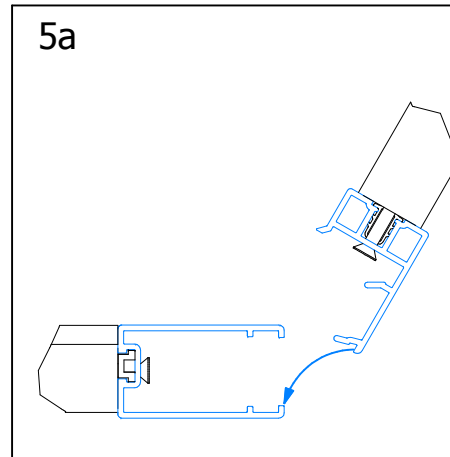
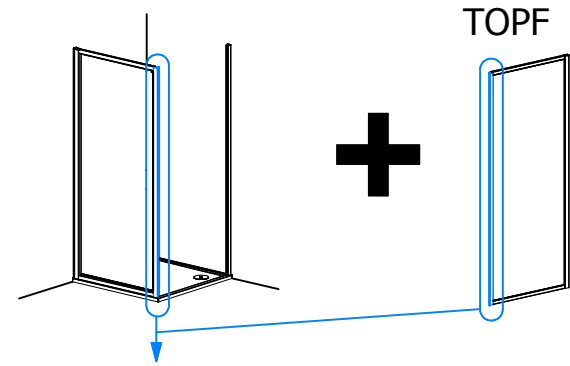

5.

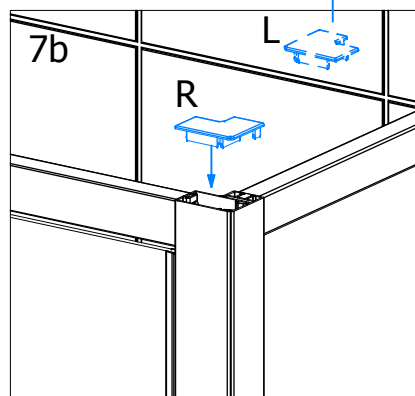
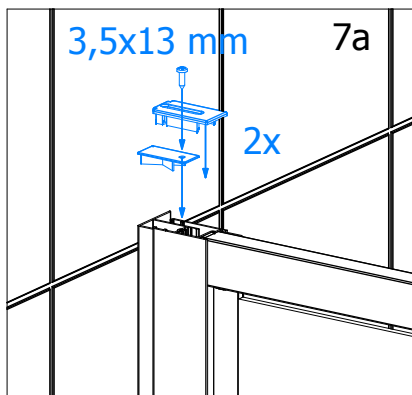

8.

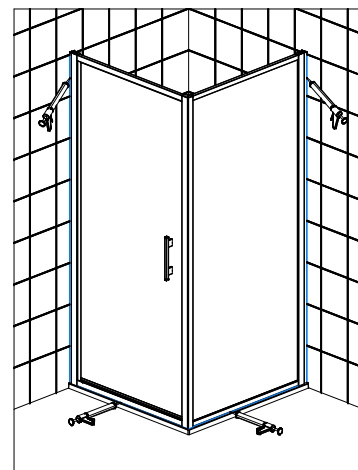

9a

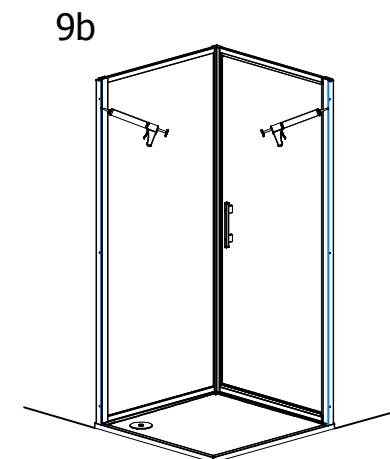

9b

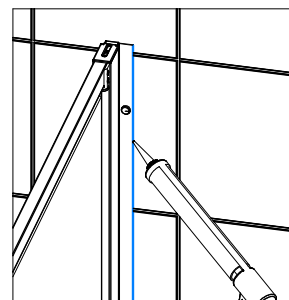

9c

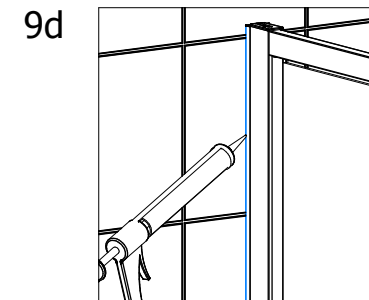

9d

Achtung! Nur Sanitär-Silikon - bakterizid und fungizid eingestellt verwenden.

Caution! Use only bactericidal and fungicide sanitary silicone.

Attention! N'utiliser que du silicone sanitaire bactéricide et fongicide.

Pozor! Používejte pouze baktericidní a fungicidní sanitární silikon.

Uwaga! Stosować tylko silikon sanitarny - bakterio i grzybobójczy.

Pozor! Užívajte pouze baktericidný a fungicidný sanitárny silikón.

Figyelem! Csak szaniter sziloplaszt - baktérium és gombamentes - használatra megengedett.

Cuidado! Utilizar solamente silicona sanitaria bactericida y fungicida.

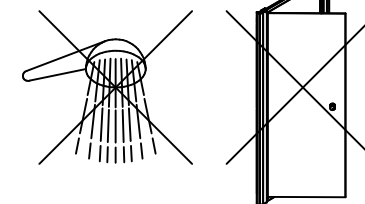

9.