

SL13+SLT1

(D) MONTAGEANLEITUNG:	DREHTÜR 1-TLG. + SEITENWAND IN FLUCHT + SEITENWAND IM WINKEL
(GB) INSTALLATION INSTRUCTIONS:	HINGED DOOR + IN LINE FIXED PANEL + FIXED PANEL IN 90°
(F) NOTICE DE MONTAGE:	PORTE PIVOTANTE + PAROI FIXE EN LIGNE + PAROI FIXE À 90°
(CZ) NÁVOD K MONTÁŽI:	OTOČNÉ DVEŘE + BOČNÍ STĚNA V ROVINĚ + BOČNÍ STĚNA 90°
(PL) INSTRUKCJA MONTAŻU:	DRZWI OBROTOWE + ŚCIANKA BOCZNA W LINIE + ŚCIANKA BOCZNA 90°
(SK) NÁVOD NA MONTÁŽ:	JEDNOKRÍDLOVÉ DVERE + PEVNÁ STENA + BOČNÁ STENA 90°
(H) SZERELÉSI ÚTMUTATÓ:	NYÍLÓAJTÓ 1-RÉSZES + OLDALFAL 180° + OLDALFAL 90°
(E) INSTRUCCIONES DE MONTAJE:	PUERTA + FIJO EN LÍNEA + FIJO A 90°



ARONAL®

Benötigtes Werkzeug:

Necessary tools:

Outil Nécessaire:

Nářadí potřebné pro montáž:

Potrzebne narzędzia:

Potrebne náradie:

Szükséges szerszámok:

Herramientas necesarias:

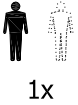

1x

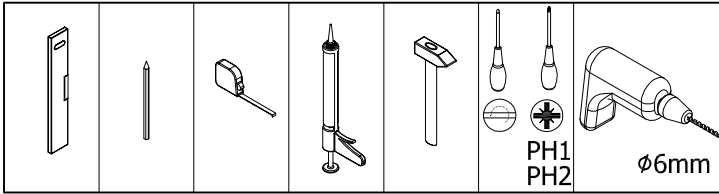

42356

51402

2x62100

50402

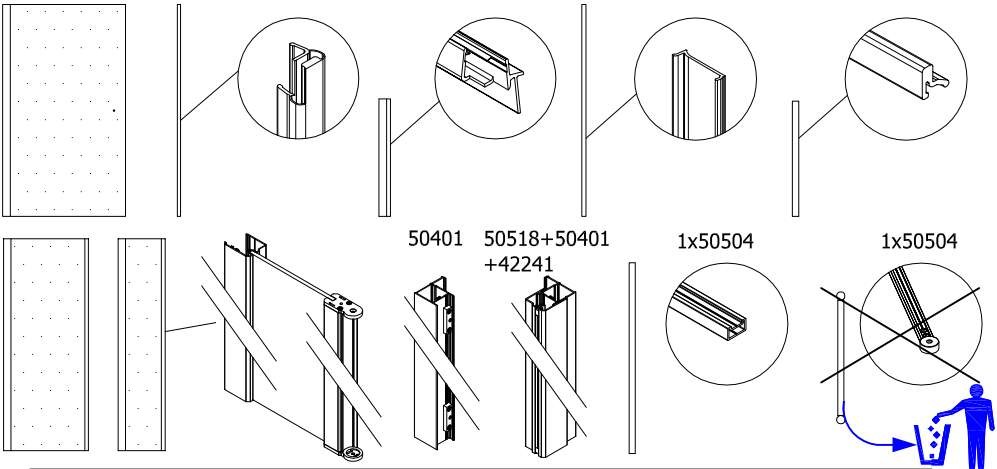

Zubehör:

Equipment:

Accessoires:

Příslušenství:

Dodatki:

Príslušenstvo:

Alkatrészek:

Accesorios:

SL1	1 x 11221	2 x 14016 3.5 x 22mm	2 x 14019 3.5 x 16mm	3 x 14027 M4 x 25mm	8 x 14118 4.2 x 32mm	2 x 14213 2.9 x 9.5mm
	8 x 16000 Ø 6mm	3 x 51209	1 x 51232+1 x 51233	1 x 51540	1 x 51541	4 x 51694
	1 x 51695+1 x 51696	1 x 51796+1 x 51797	1 x 51798 1 x 51799	1 x 54400	1 x 54401	MT0082
	1 x 51449	1 x 54406	1 x 51453	1 x 51448	1 x 54405	1 x 51452

SLT1	1 x 14016 3.5 x 22mm	2 x 14006 3.5 x 25mm	4 x 14214 M4 x 6mm	3 x 51209	1 x 51544 1 x 51545	1 x 51546 1 x 51547	1 x 51610+1 x 51611	1 x 54408+1 x 54409
------	-------------------------	-------------------------	-----------------------	-----------	------------------------	------------------------	---------------------	---------------------

1a

50518+50401+51798/99

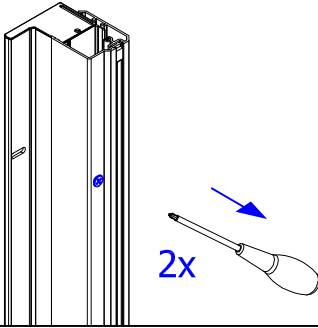

1b

50401+51798/99

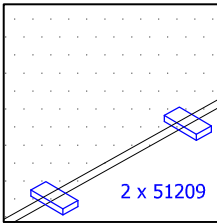
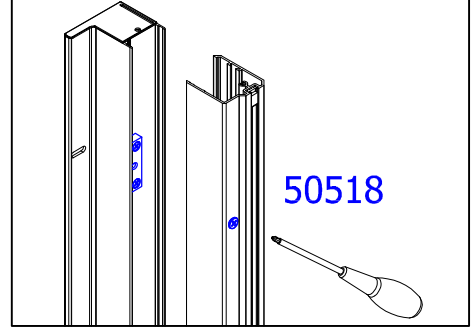

50518

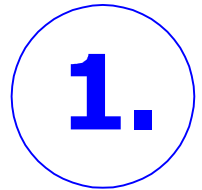

1c

51232/33

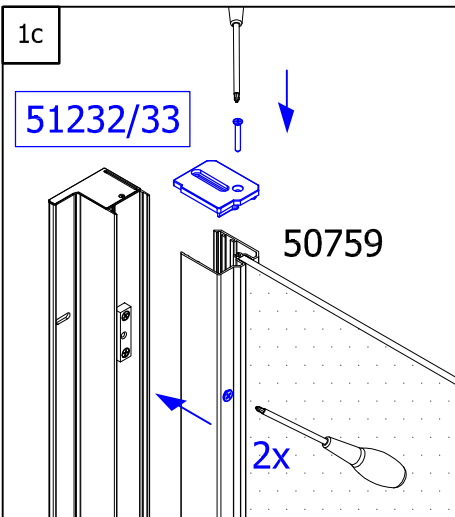

1d

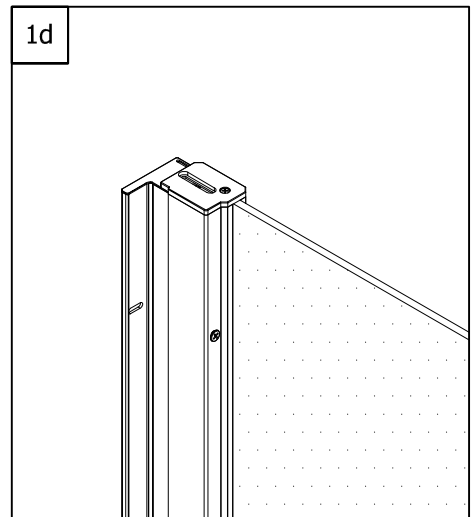

2.

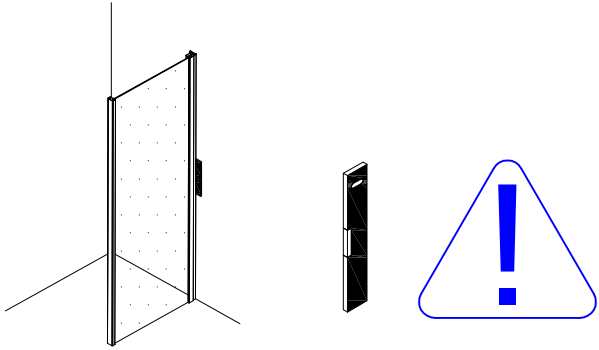

max.25mm

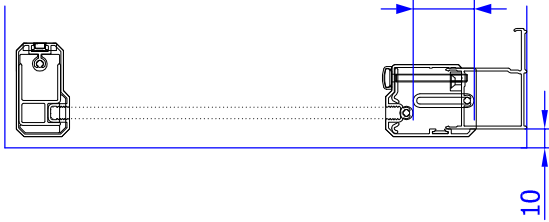

2a

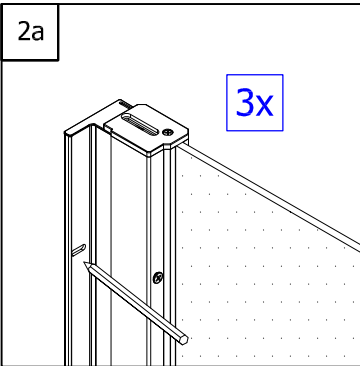

2b

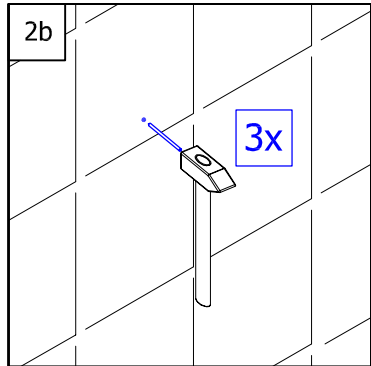

2c

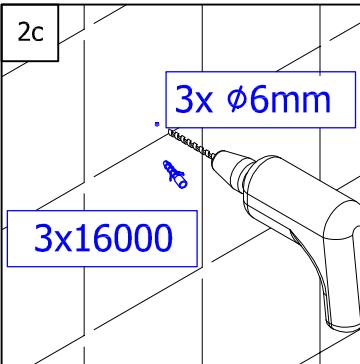

2d

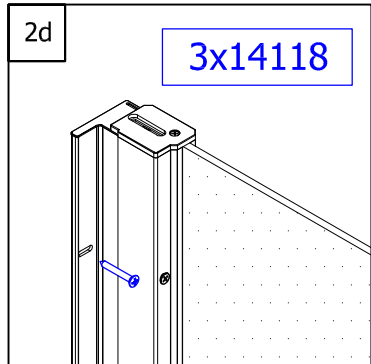

L

3.

R

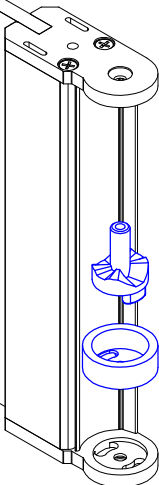
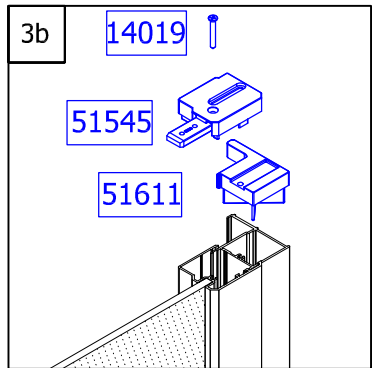
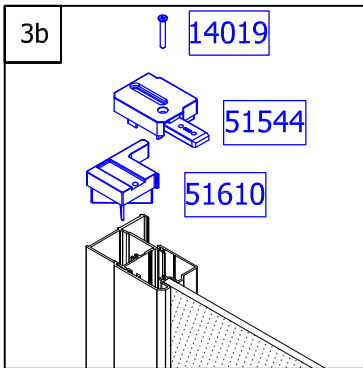
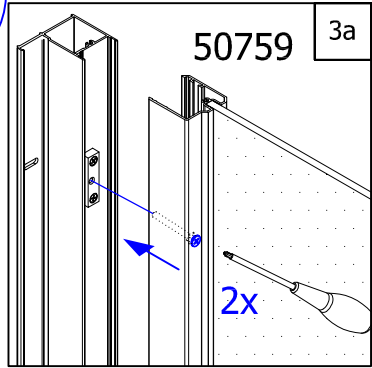
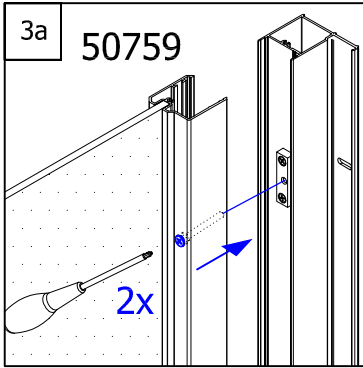

51541

54400



14027

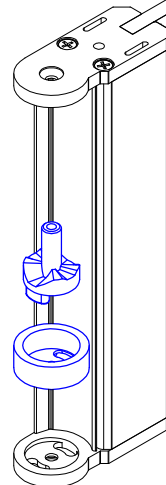

51541

54400



14027

L

4.

R

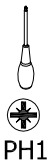
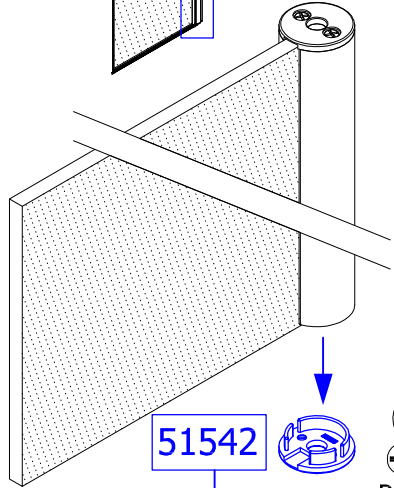
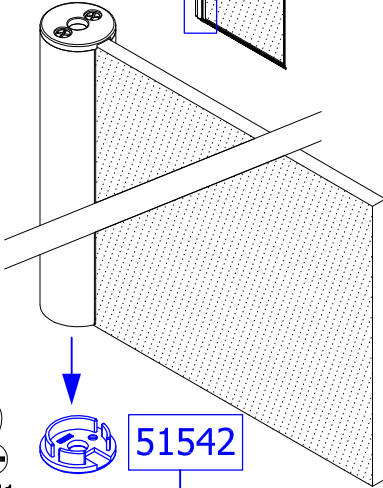
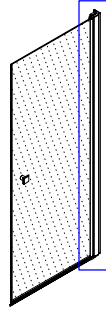
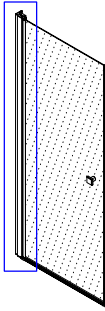

51542

51542

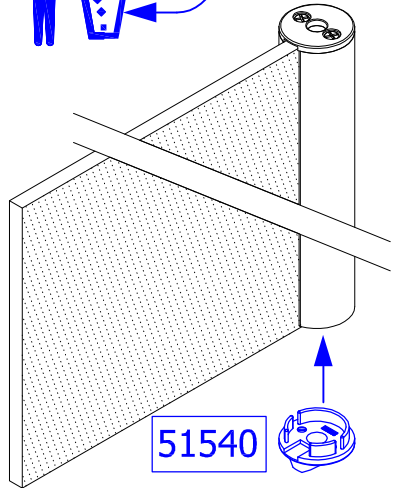
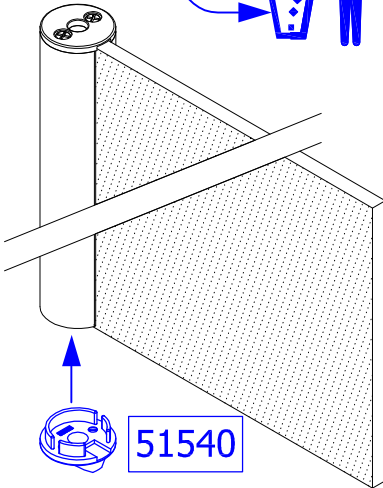

51540

51540



5.

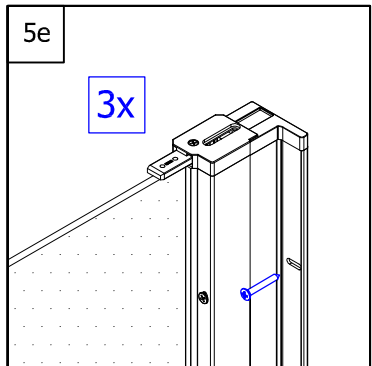
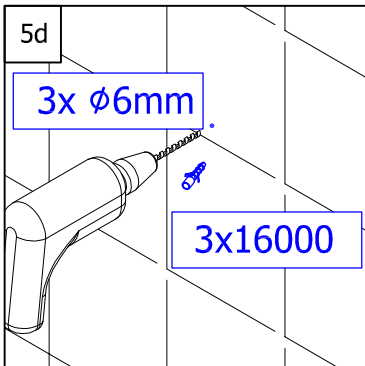
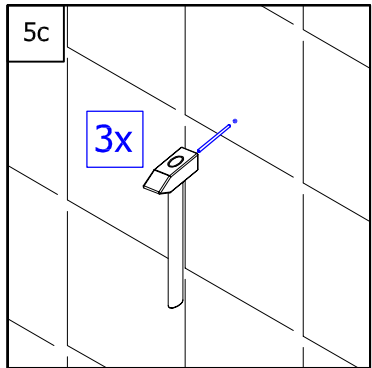
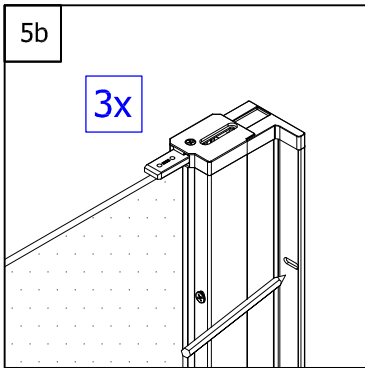
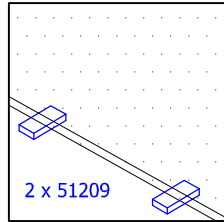
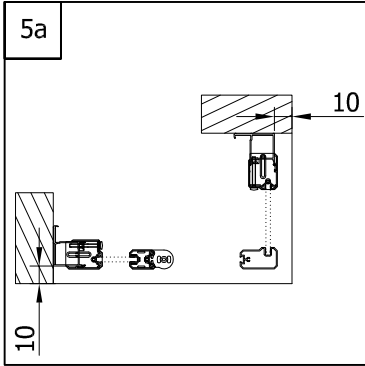
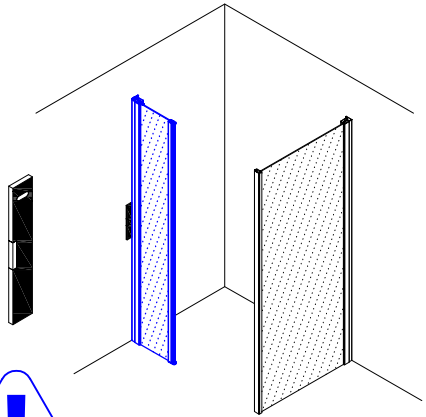

6.

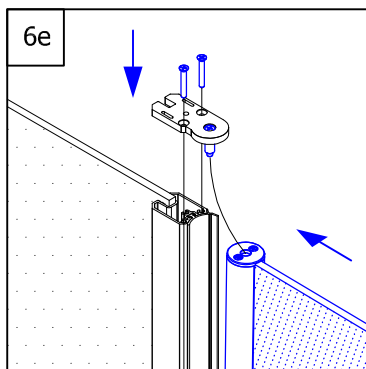
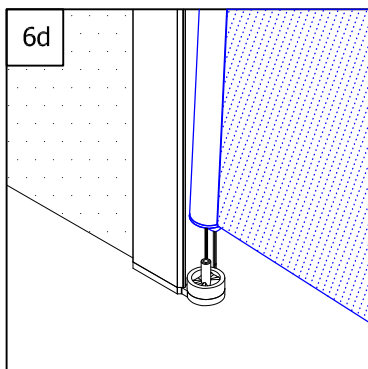
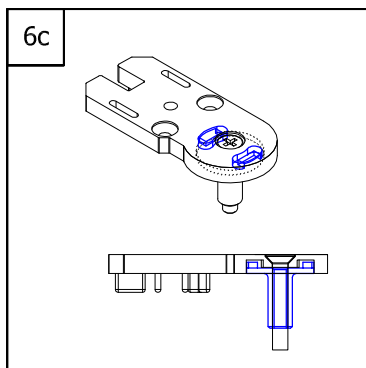
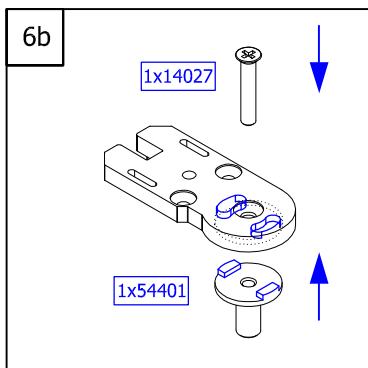
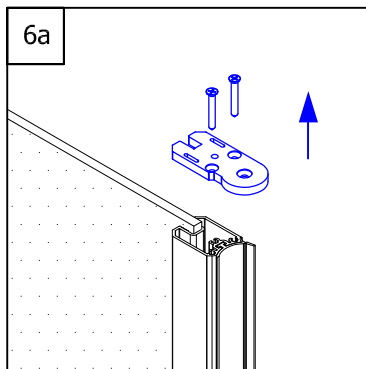
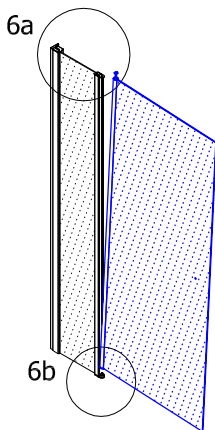

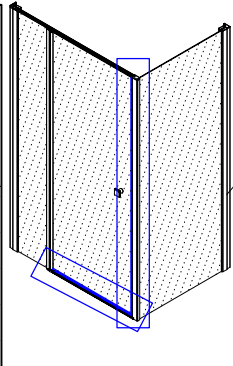
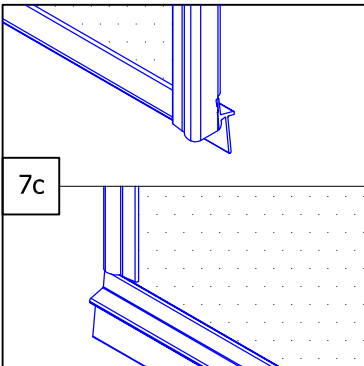
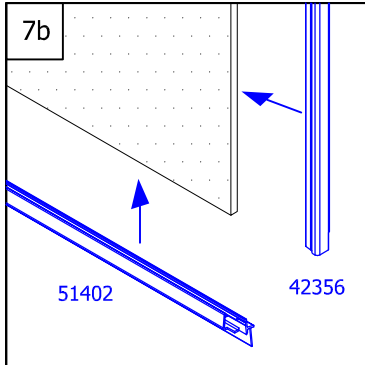
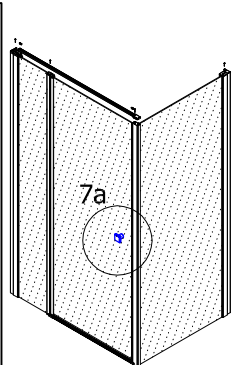
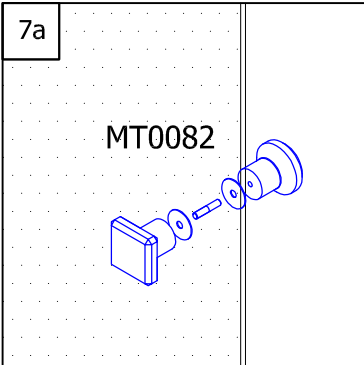

R/L 42356 R/L 51402

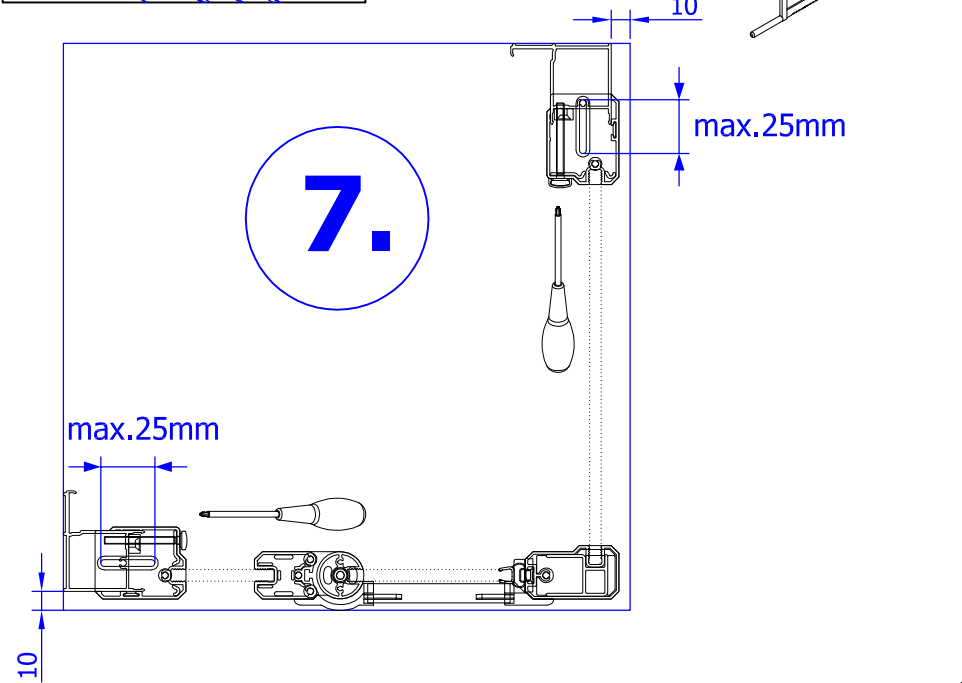
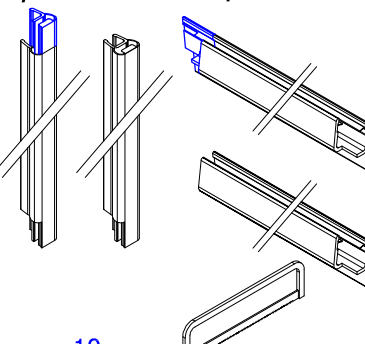

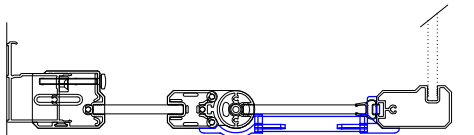
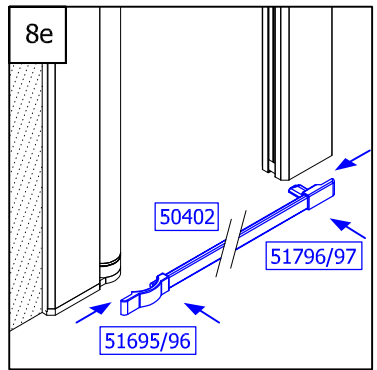
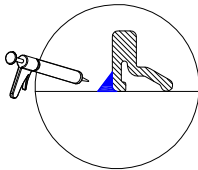
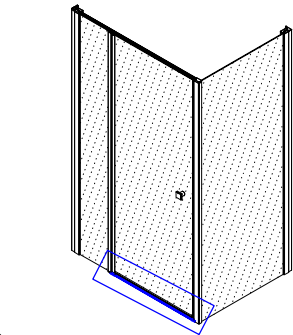
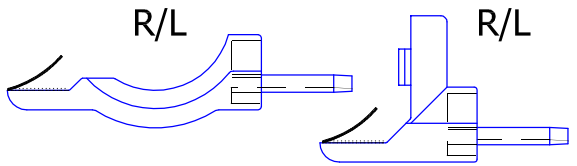
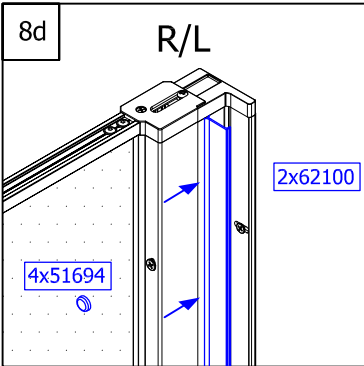
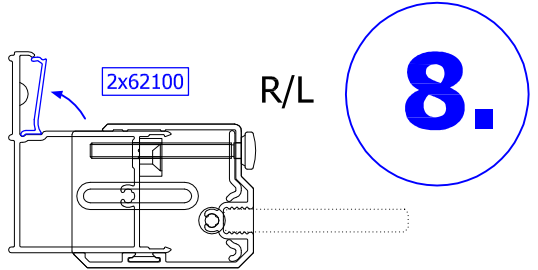
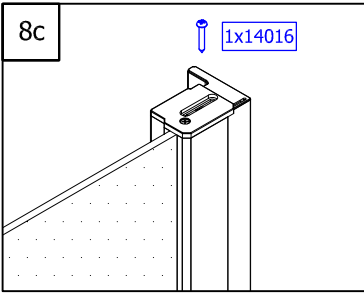
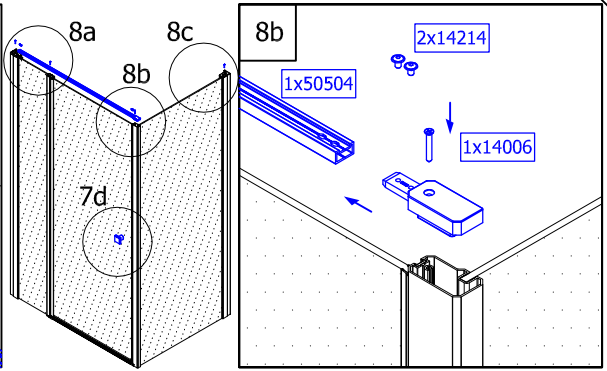
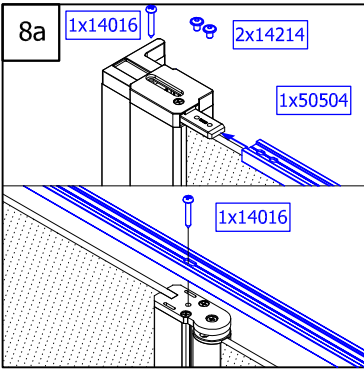

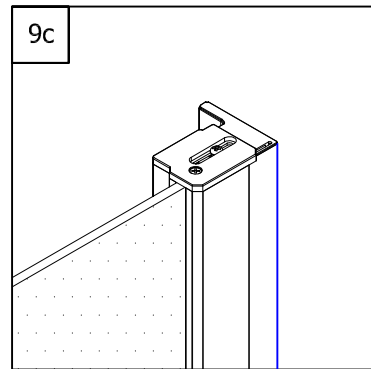
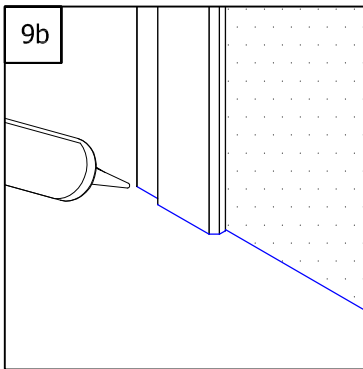
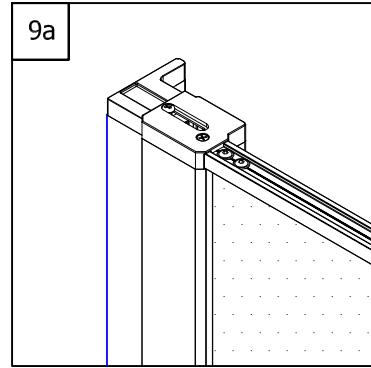
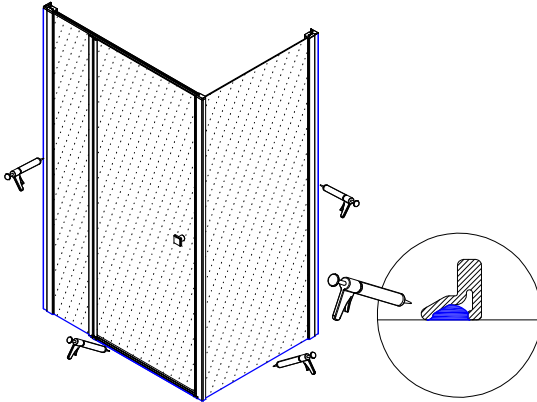

Achtung! Nur Sanitär-Silikon - bakterizid und fungizid eingestellt verwenden.

Caution! Use only bactericidal and fungicide sanitary silicone.

Attention! N'utiliser que du silicone sanitaire bactéricide et fongicide.

Pozor! Používejte pouze baktericidní a fungicidní sanitární silikon.

Uwaga! Stosować tylko silikon sanitarny - bakterio i grzybobójczy.

Pozor! Užívajte pouze baktericidný a fungicidný sanitárny silikón.

Figyelem! Csak szaniter sziloplaszt - baktérium és gombamentes - használata megengedett.

Cuidado! Utilizar solamente silicona sanitaria bactericida y fungicida.

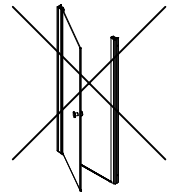
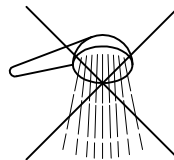

QUALITY CONTROL:

- D** Falls Sie Reklamationen haben, oder Sie unzufrieden mit Ihrem RONAL Produkt sind, beschreiben Sie bitte unten auf diesem Blatt den Produktfehler und übergeben Sie dieses Dokument Ihrem Verkäufer, oder direkt der Firma RONAL. Diese Information hilft uns, die Qualität von unseren Produkten weiter zu verbessern.
- GB** In case of a complaint or Your dissatisfaction with the RONAL product, please describe the defect below and pass this document to Your vendor, or directly to the RONAL company. This information will help us in the next increase of the quality of our products.
- F** En cas de réclamations lors de la livraison ou l'installation de votre paroi de douche RONAL, veuillez, s'il vous plaît, noter vos remarques au bas de la feuille et transmettre les informations à votre revendeur. Elles nous permettront d'améliorer notre qualité et par la même notre service.
- CZ** V případě reklamace, či Vaší nespokojenosti s výrobkem RONAL popište prosím ve spodní části tohoto listu závadu a dokument prosím odevzdejte Vašemu prodejci nebo přímo firmě RONAL. Tato informace nám pomůže v dalším zvýšení kvality našich výrobků.
- PL** Reklamacje , oraz inne niezgoności związane z produktem RONAL prosimy przekazywać sprzedawcy na załącznym druku.
- SK** V prípade reklamácie, alebo Vašej nespokojnosti s výrobkom RONAL, popíšte prosím v spodnej časti tohto listu závalu a dokument prosím odovzdajte Vašemu prodejci, alebo priamo firme RONAL. Táto informácia nám pomôže v ďalšom zvýšení kvality našich výrobkov.
- H** Abban az esetben ha reklamációja vagy panasza van az Ön által vásárolt RONAL termékkel, úgy azt írja meg a lap alján található helyre és adja át a kereskedőjének, vagy küldje el közvetlenül a RONAL cégnek! Ez az információ segít nekünk termékeink minőségének javításában.
- E** En caso de reclamaciones ó si no está satisfecho con su producto RONAL, por favor describan en la parte inferior de esta hoja el fallo del producto y entreguen este documento a su vendedor ó directamente a la empresa RONAL. Esta información nos ayuda a seguir mejorando la calidad de nuestros productos.

.....

.....

.....

.....

.....

.....

.....

.....

.....

.....

.....