

SALSA 3

(D) MONTAGEANLEITUNG:	FREI BEGEBBARE DUSCHE 2-TEILIG MIT DREHTÜR
(GB) INSTALLATION INSTRUCTIONS:	TWO-PART SHOWER WITH SWING DOOR
(F) NOTICE DE MONTAGE:	PAROI DE DOUCHE SANS FERMETURE AVEC PIVOTANT BOMBÉ
(CZ) NÁVOD K MONTÁŽI:	DVOUDÍLNÁ ZÁSTĚNA S KRÍDLOVÝMI DVEŘMI
(PL) INSTRUKCJA MONTAŻU:	DWUCZĘŚCIOWA KABINA Z DRZWIAMI OTWIERANYMI
(SK) NÁVOD NA MONTÁŽ:	DVOJDIELNA ZÁSTĚNA S KRÍDLOVÝMI DVERAMI
(H) SZERELÉSI ÚTMUTATÓ:	2 FIX RÉSZBŐL ÁLLÓ ZUHANYKABIN
(E) INSTRUCCIONES DE MONTAJE:	CONJUNTO DE 3 PIEZAS DOS FIJAS + PUERTA MOVIL

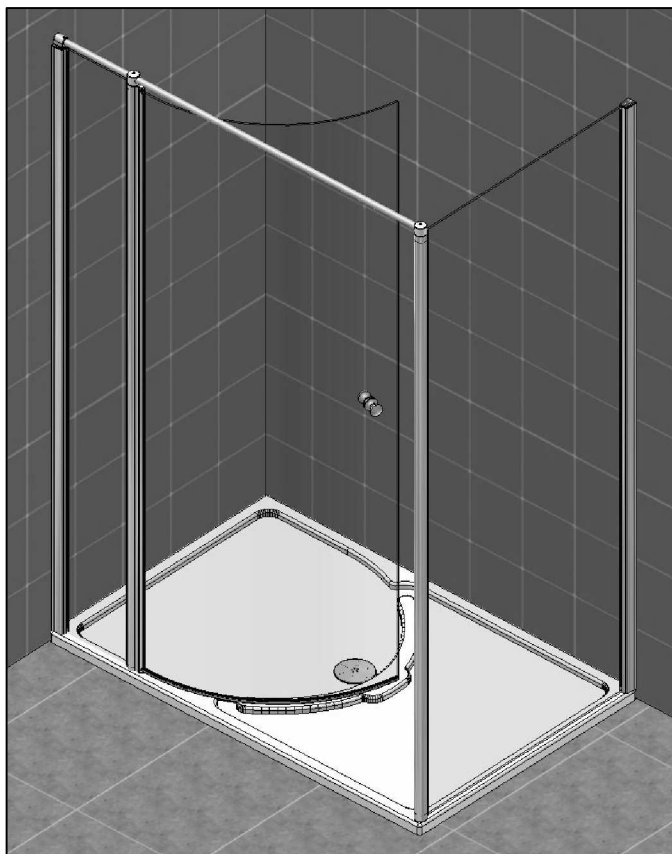

ERONAL®

Benötigtes Werkzeug:

Necessary tools:

Outil Nécessaire:

Nářadí potřebné pro montáž:

Potrzebne narzędzia:

Potrebne náradie:

Szükséges szerszámok:

Herramientas necesarias:

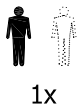

1x

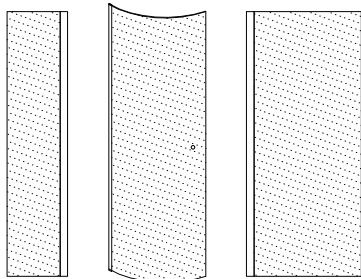
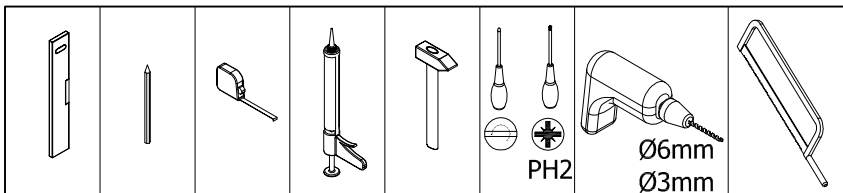

2 x 50352

2 x 50459

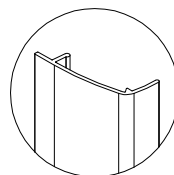
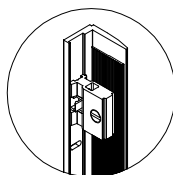

1 x 10260



1 x 51402

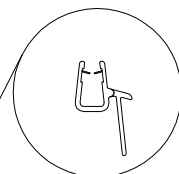

Zubehör:

Equipment:

Accessoires:









Příslušenství:

Dodatki:

Príslušenstvo:

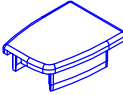
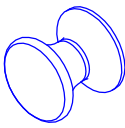
Alkatrészek:

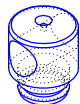
Accesorios:

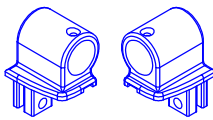
 1 x 11221	 1 x 14154 M6 x 20	 8 x 14139 4.2 x 50mm	 3 x 14009 3.5 x 9.5mm	 8 x 16000 Ø 6mm	 L/R 2 x 51590-91
 2 x 14065	 2 x 94101	 1 x 14033	 1 x 54002	 1 x 54003	 2 x 54102-103

1.

"L"

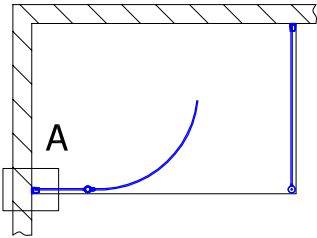

"R"

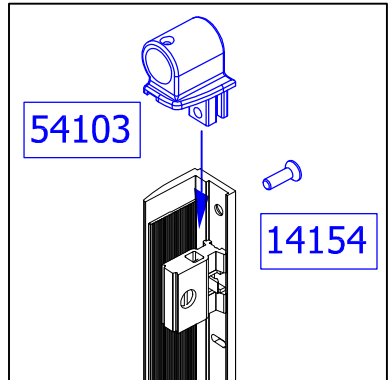
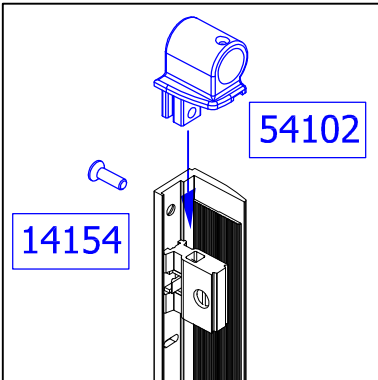
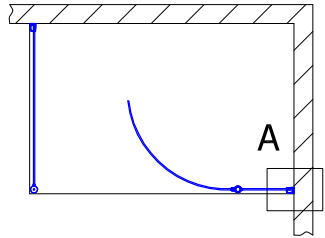

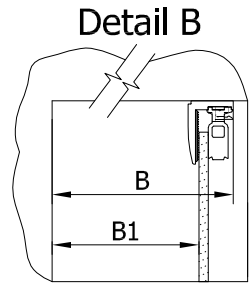
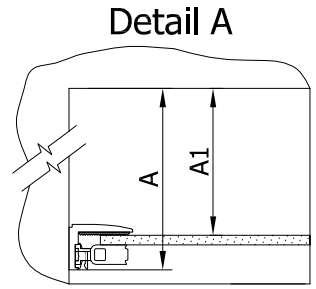
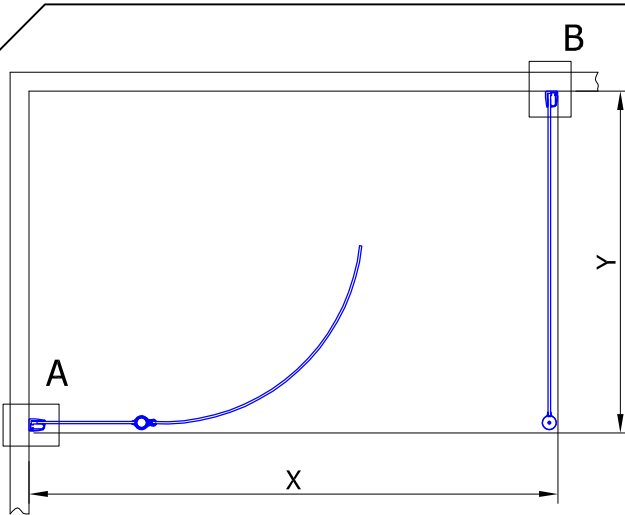

2.

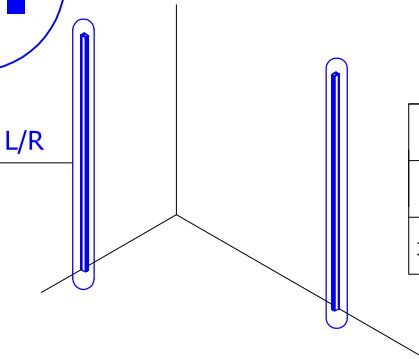

$X \times Y$	A	A1	B	B1
1400x900	897	874	1397	1374
1400x1000	997	974	1397	1374

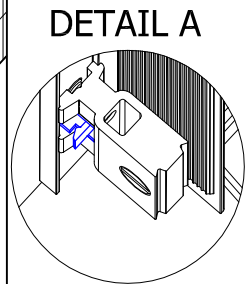
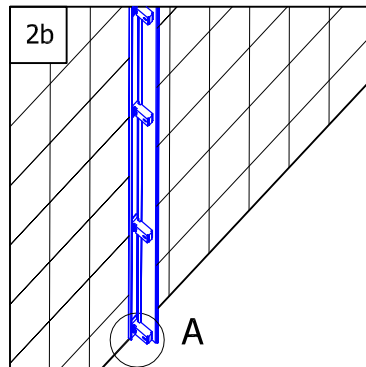
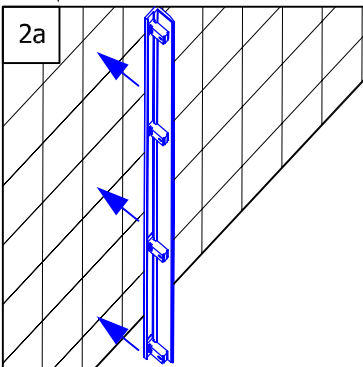

2c

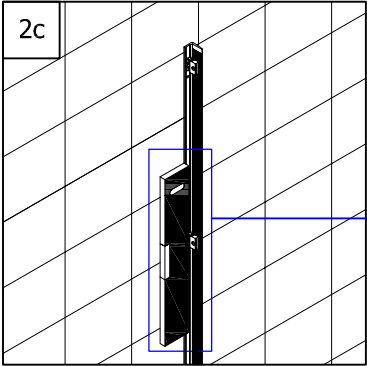

2d

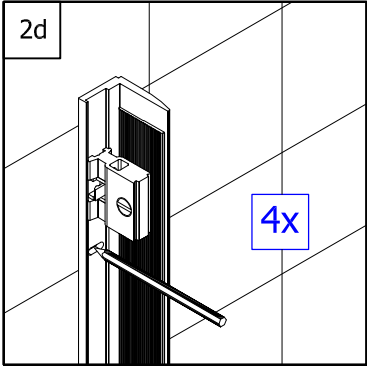

3.

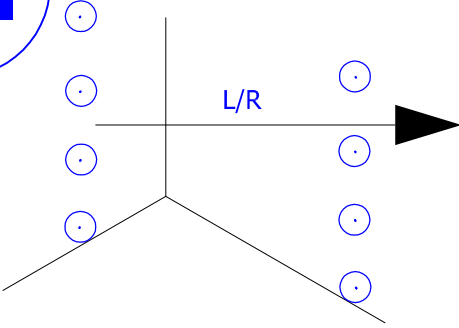

3a

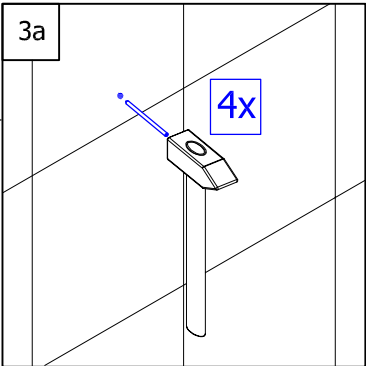

3b

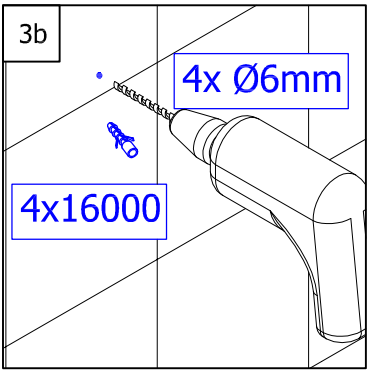

3c

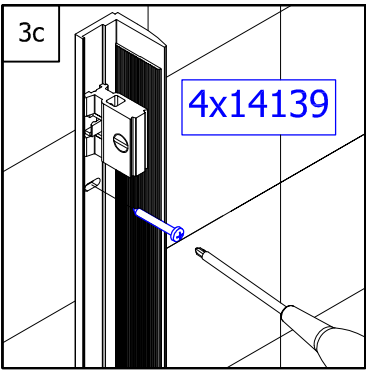

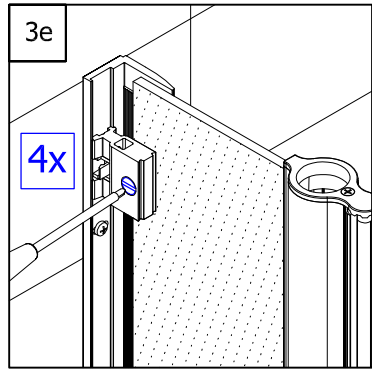
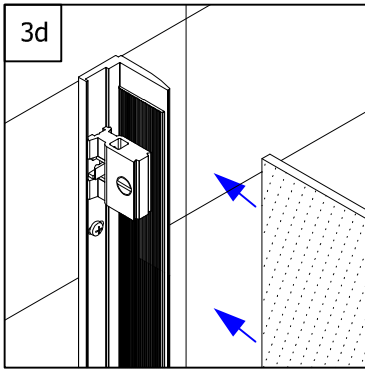

4.

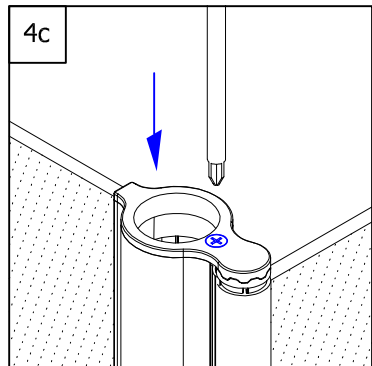
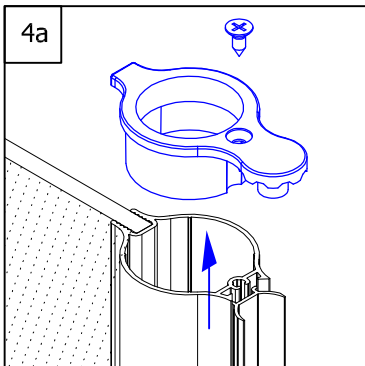
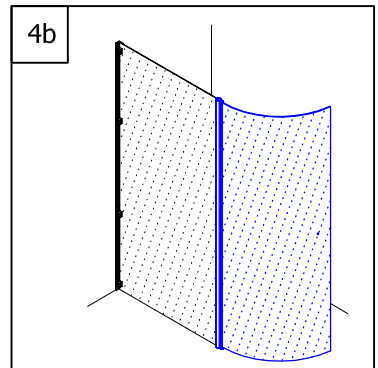
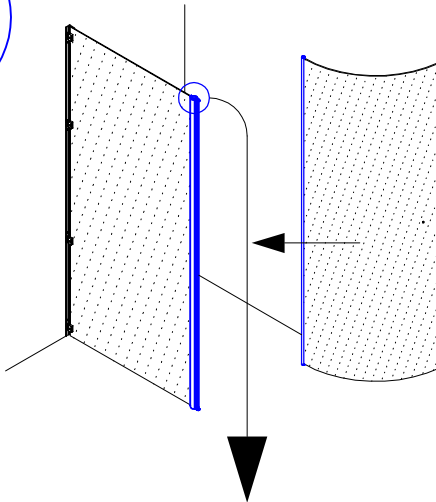

5.

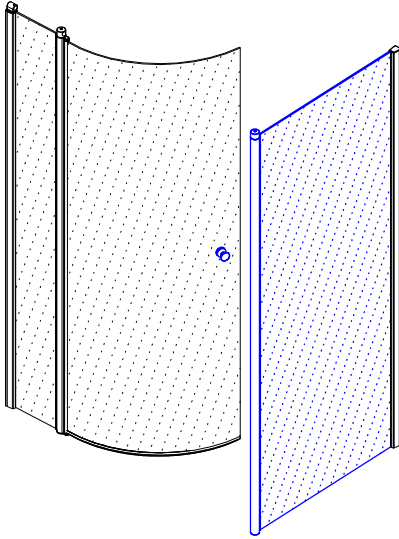

5a

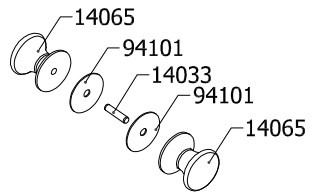

5b

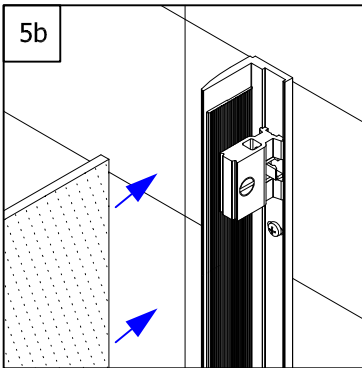

5c

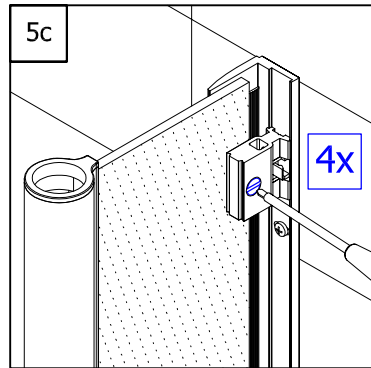

-15mm

ok

min

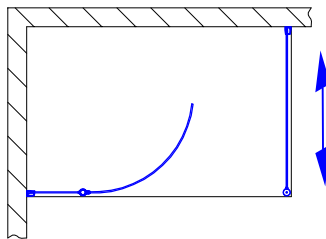

+5mm

ok

max

6.

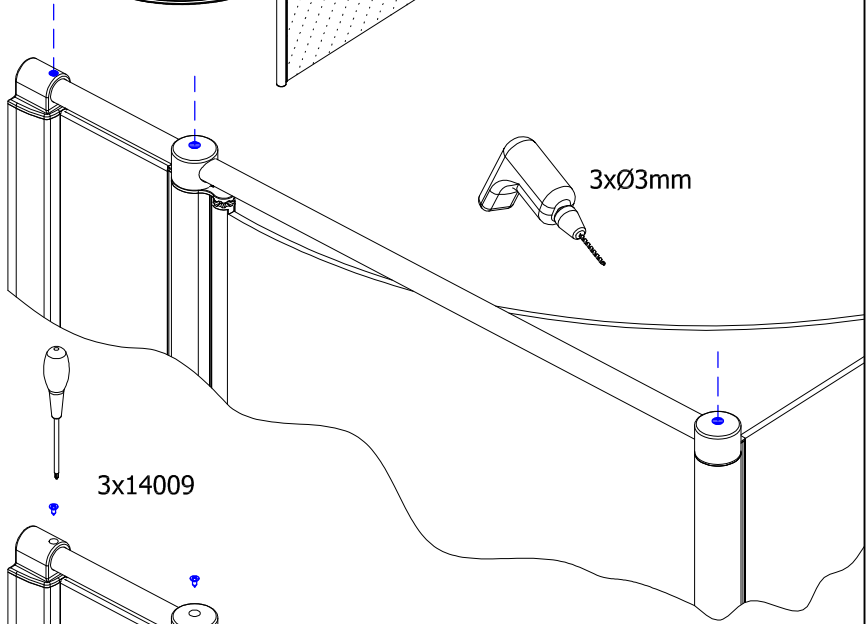
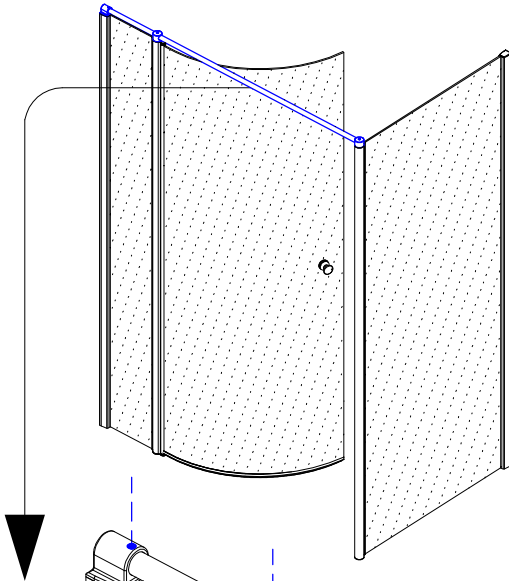

3xØ3mm



3x14009

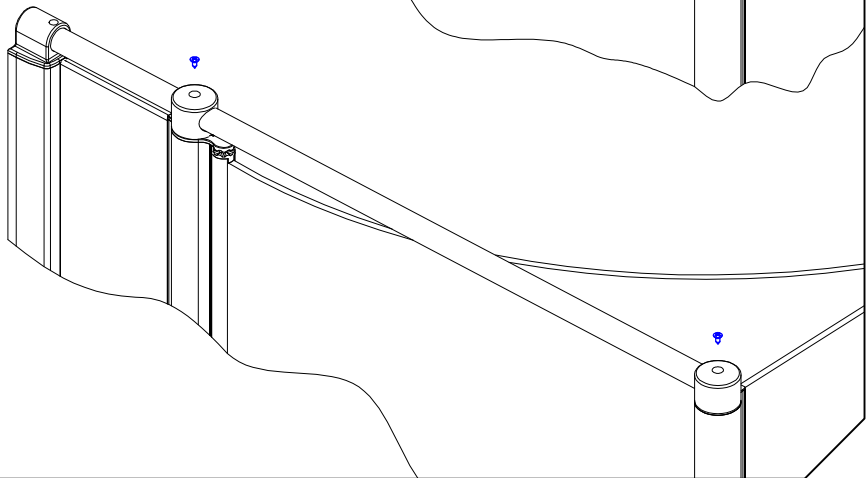

7.

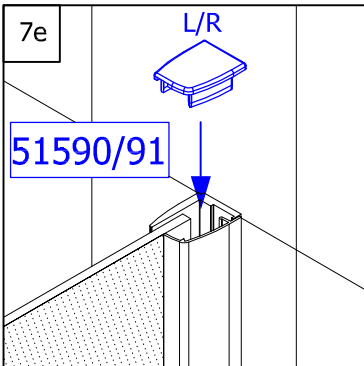
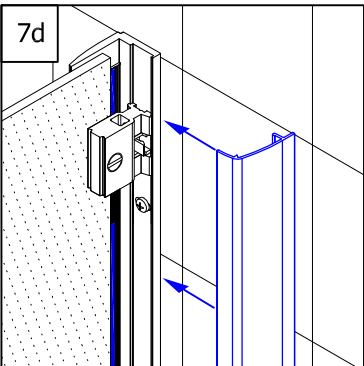
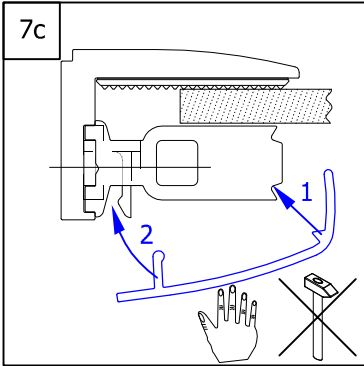
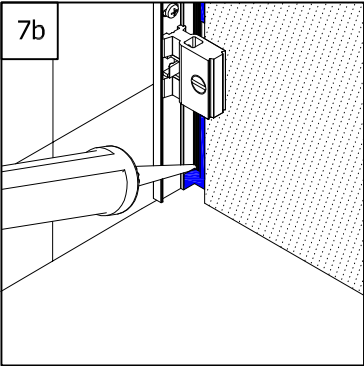
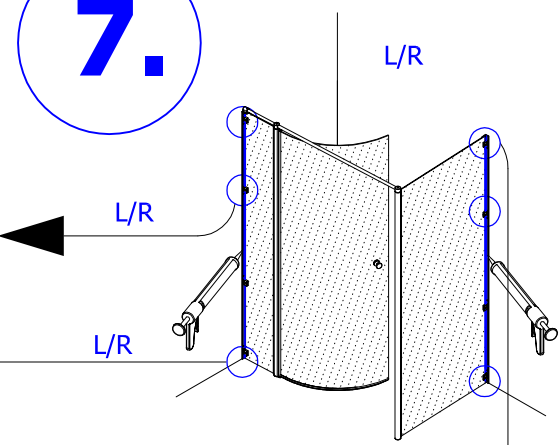
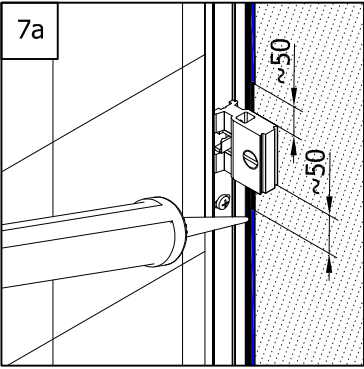

8a

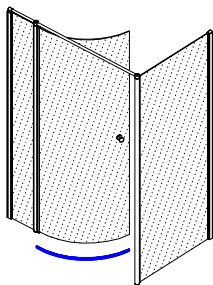

51402



8b

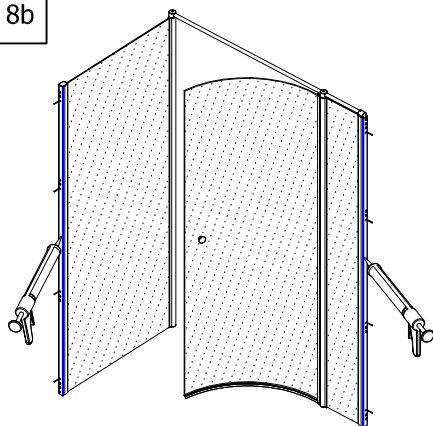

8c

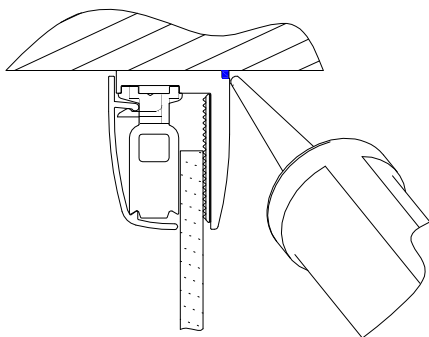
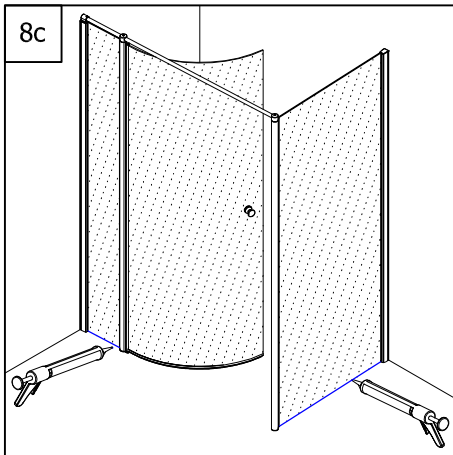

Achtung! Nur Sanitär-Silikon - bakterizid und fungizid eingestellt verwenden.

Caution! Use only bactericidal and fungicidal sanitary silicone.

Attention! N'utiliser que du silicone sanitaire bactéricide et fongicide.

Pozor! Používejte pouze baktericidní a fungicidní sanitární silikon.

Uwaga! Stosować tylko silikon sanitarny - bakterio- i grzybobójczy.

Pozor! Užívajte pouze baktericidný a fungicidný sanitárny silikón.

Figyelem! Csak szaniter sziloplaszt - baktérium és gombamentes - használata megengedett.

Cuidado! Utilizar solamente silicona sanitaria bactericida y fungicida.

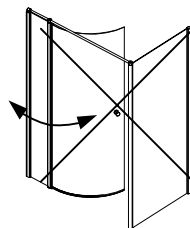
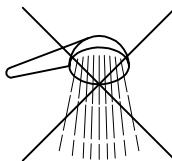

8.

QUALITY CONTROL:

- D** Falls Sie Reklamationen haben, oder Sie unzufrieden mit Ihrem RONAL Produkt sind, beschreiben Sie bitte unten auf diesem Blatt den Produktfehler und übergeben Sie dieses Dokument Ihrem Verkäufer, oder direkt der Firma RONAL. Diese Information hilft uns, die Qualität von unseren Produkten weiter zu verbessern.
- GB** In case of a complaint or Your dissatisfaction with the RONAL product, please describe the defect below and pass this document to Your vendor, or directly to the RONAL company. This information will help us in the next increase of the quality of our products.
- F** En cas de réclamations lors de la livraison ou l'installation de votre paroi de douche RONAL, veuillez, s'il vous plaît, noter vos remarques au bas de la feuille et transmettre les informations à votre revendeur. Elles nous permettront d'améliorer notre qualité et par la même notre service.
- CZ** V případě reklamace, či Vaší nespokojenosti s výrobkem RONAL popište prosím ve spodní části tohoto listu závadu a dokument prosím odevzdejte Vašemu prodejci nebo přímo firmě RONAL. Tato informace nám pomůže v dalším zvýšení kvality našich výrobků.
- PL** Reklamacje , oraz inne niezgoności związane z produktem RONAL prosimy przekazywać sprzedawcy na załącznym druku.
- SK** V prípade reklamácie, alebo Vašej nespokojnosti s výrobkom RONAL, popíšte prosím v spodnej časti tohto listu závalu a dokument prosím odovzdajte Vašemu prodejci, alebo priamo firme RONAL. Táto informácia nám pomôže v ďalšom zvýšení kvality našich výrobkov.
- H** Abban az esetben ha reklamációja vagy panasza van az Ön által vásárolt RONAL termékkel, úgy azt írja meg a lap alján található helyre és adja át a kereskedőjének, vagy küldje el közvetlenül a RONAL cégnek! Ez az információ segít nekünk termékeink minőségének javításában.
- E** En caso de reclamaciones ó si no está satisfecho con su producto RONAL, por favor describan en la parte inferior de esta hoja el fallo del producto y entreguen este documento a su vendedor ó directamente a la empresa RONAL. Esta información nos ayuda a seguir mejorando la calidad de nuestros productos.

.....

.....

.....

.....

.....

.....

.....

.....

.....

.....

.....